

Operating Instructions Basic Guide

Touch Screen LCD Display For business use

English

Model No.	TH-80BF1U	80-inch model
	TH-65BF1U	65-inch model
	TH-50BF1U	50-inch model
	TH-80BF1E	80-inch model
	TH-65BF1E	65-inch model
	TH-50BF1E	50-inch model
	TH-80BF1W	80-inch model
	TH-65BF1W	65-inch model
	TH-50BF1W	50-inch model

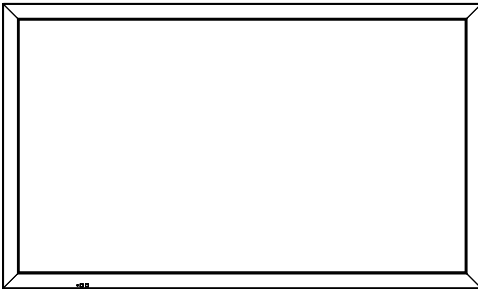

Contents

Important Safety Instructions.....	2
FCC STATEMENT.....	3
Important Safety Notice.....	5
Safety Precautions	6
Precautions for use.....	10
Accessories	15
Connections.....	19
Power On / Off.....	24
Basic Controls	26
Specifications	29
Software License	32
Panasonic Professional Flat Panel Display Limited Warranty.....	33
LIMITED WARRANTY STATEMENT ...	34
Customer Service.....	35

**For more detailed instructions, refer to the
Operating Instructions on the CD-ROM.**

- Please read these instructions before operating your set and retain them for future reference.
- Illustrations and screens in this Operating Instructions are images for illustration purposes, and may be different from the actual ones.
- Descriptive illustrations in this Operating Instructions are created mainly based on the 50-inch model.



HDMI

DPQX1036ZC



The lightning flash with arrow-head within a triangle is intended to tell the user that parts inside the product are a risk of electric shock to persons.



The exclamation point within a triangle is intended to tell the user that important operating and servicing instructions are in the papers with the appliance.

WARNING : To prevent damage which may result in fire or shock hazard, do not expose this apparatus to rain or moisture.

Do not place containers with water (flower vase, cups, cosmetics, etc.) above the set. (including on shelves above, etc.)

WARNING : 1) To prevent electric shock, do not remove cover. No user serviceable parts inside. Refer servicing to qualified service personnel.

2) Do not remove the grounding pin on the power plug. This apparatus is equipped with a three pin grounding-type power plug. This plug will only fit a grounding-type power outlet. This is a safety feature. If you are unable to insert the plug into the outlet, contact an electrician. Do not defeat the purpose of the grounding plug.

Important Safety Instructions

- 1) Read these instructions.
- 2) Keep these instructions.
- 3) Heed all warnings.
- 4) Follow all instructions.
- 5) Do not use this apparatus near water.
- 6) Clean only with dry cloth.
- 7) Do not block any ventilation openings. Install in accordance with the manufacturer's instructions.
- 8) Do not install near any heat sources such as radiators, heat registers, stoves, or other apparatus (including amplifiers) that produce heat.
- 9) Do not defeat the safety purpose of the polarized or grounding-type plug. A polarized plug has two blades with one wider than the other. A grounding type plug has two blades and a third grounding prong. The wide blade or the third prong are provided for your safety. If the provided plug does not fit into your outlet, consult an electrician for replacement of the obsolete outlet.
- 10) Protect the power cord from being walked on or pinched particularly at plugs, convenience receptacles, and the point where they exit from the apparatus.
- 11) Only use attachments / accessories specified by the manufacturer.
- 12) Use only with the cart, stand, tripod, bracket, or table specified by the manufacturer, or sold with the apparatus. When a cart is used, use caution when moving the cart / apparatus combination to avoid injury from tip-over.
- 13) Unplug this apparatus during lightning storms or when unused for long periods of time.
- 14) Refer all servicing to qualified service personnel. Servicing is required when the apparatus has been damaged in any way, such as power-supply cord or plug is damaged, liquid has been spilled or objects have fallen into the apparatus, the apparatus has been exposed to rain or moisture, does not operate normally, or has been dropped.
- 15) To prevent electric shock, ensure the grounding pin on the AC cord power plug is securely connected.



FCC STATEMENT

This equipment has been tested and found to comply with the limits for a class A digital device, pursuant to Part 15 of the FCC Rules. These limits are designed to provide reasonable protection against harmful interference when the equipment is operated in a commercial environment. This equipment generates, uses and can radiate radio frequency energy and, if not installed and used in accordance with the instructions manual, may cause harmful interference to radio communications. Operation of this equipment in a residential area is likely to cause harmful interference in which case the user will be required to correct the interference at his own expense.

FCC CAUTION:

To assure continued compliance, follow the attached installation instructions and use only the provided power supply cord. Any changes or modifications not expressly approved by Panasonic Corp. of North America could void the user's authority to operate this device.

FCC and Industry Canada (IC) RF Exposure

Warning:

- **This Display is provided with built-in transmitter:**
 - Wireless LAN Adapter with FCC ID:**
H8N-WLU5150/IC ID:1353A-WLU5150;
- **This transmitter complies with FCC and IC radiation exposure limits set forth for an uncontrolled environment for mobile use with minimum 8 inches (20 cm) spacing requirement between transmitter and all person's body (excluding extremities of hands, wrist and feet) during wireless modes of operation.**
- **Other third-party wireless transmitters should not be used as they have not been RF exposure evaluated for use with this Display and may not comply with RF exposure requirements.**

<Only for wireless LAN if capable of transmission in the 5.15 ~ 5.25 GHz frequency band>

This product is restricted to indoor use due to its operation in the 5.15 to 5.25 GHz frequency range.

IC requires this product to be used indoors for the frequency range 5.15 to 5.25 GHz to reduce the potential for harmful interference to co-channel Mobile Satellite systems. High power radars are allocated as primary users of the 5.25 to 5.35 GHz and 5.65 to 5.85 GHz bands. These radar stations can cause interference with and/or damage this product.

Declaration of Verification

Model No. TH-80BF1U, TH-65BF1U, TH-65BF1U
Responsible Party: Panasonic Corporation of North America
Two Riverfront Plaza, Newark, New Jersey
07102-5490
Contact Source: Panasonic System Communications Company of North America
1-877-655-2357
General Contact: <http://shop.panasonic.com/support>

This device complies with Part 15 of the FCC Rules and all applicable IC RSS standards. Operation is subject to the following two conditions: (1) This device may not cause harmful interference, and (2) this device must accept any interference received, including interference that may cause undesired operation.

FCC STATEMENT

CANADIAN NOTICE:

This Class A digital apparatus complies with Canadian ICES-003.

WARNING:

- Not for use in a computer room as defined in the Standard for the Protection of Electronic Computer/Data Processing Equipment, ANSI/NFPA 75.
- For permanently connected equipment, a readily accessible disconnect device shall be incorporated in the building installation wiring.
- For pluggable equipment, the socket-outlet shall be installed near the equipment and shall be easily accessible.

Note:

Image retention may occur. If you display a still picture for an extended period, the image might remain on the screen. However, it will disappear when a general moving picture is displayed for a while.

Trademark Credits

- HDMI, the HDMI Logo, and High-Definition Multimedia Interface are trademarks or registered trademarks of HDMI Licensing LLC in the United States and other countries.
 - RoomView, Crestron RoomView are registered trademarks of Crestron Electronics, Inc.
 - Crestron Connected™ and Fusion RV are trademarks of Crestron Electronics, Inc.
 - Wi-Fi®, Wi-Fi Direct™ and Miracast™ are registered trademarks or trademarks of Wi-Fi Alliance.
 - Windows, Windows Vista, Internet Explorer, PowerPoint, Microsoft Word and Microsoft Excel are registered trademarks or trademarks of Microsoft Corporation in the United States and other countries.
 - Mac, Mac OS, OS X, iPad, iPhone, iPod touch and Safari are trademarks of Apple Inc., registered in the United States and other countries.
 - iOS is a trademark and registered trademark of Cisco in the United States and other countries and is used under license.
 - Android is a trademark of Google Inc.
 - Adobe, Adobe Flash Player and Adobe Reader are trademarks or registered trademarks of Adobe Systems Inc. in the United States and/or other countries.
 - Intel and the Intel logo are trademarks of Intel Corporation in the U.S. and/or other countries.
- Even if no special notation has been made of company or product trademarks, these trademarks have been fully respected.

Important Safety Notice

WARNING

- 1) To prevent damage which may result in fire or shock hazard, do not expose this appliance to dripping or splashing. Do not place containers with water (flower vase, cups, cosmetics, etc.) above the set. (including on shelves above, etc.)
No naked flame sources, such as lighted candles, should be placed on / above the set.
- 2) To prevent electric shock, do not remove cover. No user serviceable parts inside. Refer servicing to qualified service personnel.
- 3) Do not remove the earthing pin on the power plug. This apparatus is equipped with a three pin earthing-type power plug. This plug will only fit an earthing-type power outlet. This is a safety feature. If you are unable to insert the plug into the outlet, contact an electrician.
Do not defeat the purpose of the earthing plug.
- 4) To prevent electric shock, ensure the earthing pin on the AC cord power plug is securely connected.

CAUTION

This appliance is intended for use in environments which are relatively free of electromagnetic fields. Using this appliance near sources of strong electromagnetic fields or where electrical noise may overlap with the input signals could cause the picture and sound to wobble or cause interference such as noise to appear. To avoid the possibility of harm to this appliance, keep it away from sources of strong electromagnetic fields.

WARNING:

This equipment is compliant with Class A of CISPR32. In a residential environment this equipment may cause radio interference.

IMPORTANT INFORMATION

If a display is not positioned in a sufficiently stable location, it can be potentially hazardous due to falling. Many injuries, particularly to children, can be avoided by taking simple precautions such as:

- Using cabinets or stands recommended by the manufacturer of the display.
- Only using furniture that can safely support the display.
- Ensuring the display is not overhanging the edge of the supporting furniture.
- Not placing the display on tall furniture (for example, cupboards or bookcases) without anchoring both the furniture and the display to a suitable support.
- Not standing the displays on cloth or other materials placed between the display and supporting furniture.
- Educating children about the dangers of climbing on furniture to reach the display or its controls.

IMPORTANT: THE MOULDED PLUG

FOR YOUR SAFETY, PLEASE READ THE FOLLOWING TEXT CAREFULLY.

This display is supplied with a moulded three pin mains plug for your safety and convenience. A 10 amp fuse is fitted in this plug. Shall the fuse need to be replaced, please ensure that the replacement fuse has a rating of 10 amps and that it is approved by ASTA or BSI to BS1362.

Check for the ASTA mark  or the BSI mark  on the body of the fuse.

If the plug contains a removable fuse cover, you must ensure that it is refitted when the fuse is replaced.

If you lose the fuse cover the plug must not be used until a replacement cover is obtained.

A replacement fuse cover can be purchased from your local Panasonic dealer.

Do not cut off the mains plug.

Do not use any other type of mains lead except the one supplied with this display.

The supplied mains lead and moulded plug are designed to be used with this display to avoid interference and for your safety.

If the socket outlet in your home is not suitable, get it changed by a qualified electrician.

If the plug or mains lead becomes damaged, purchase a replacement from an authorized dealer.

WARNING : — THIS DISPLAY MUST BE EARTHED.

How to replace the fuse. Open the fuse compartment with a screwdriver and replace the fuse.

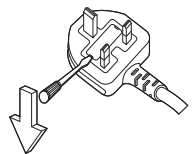

Safety Precautions

WARNING

■ Setup

This LCD Display is for use only with the following optional accessories. Use with any other type of optional accessories may cause instability which could result in the possibility of injury.

(All of the following accessories are manufactured by Panasonic Corporation.)

• Pedestal	(50-inch model) TY-ST42P50*1 *2 (80-inch model) (65-inch model) TY-ST65P20
• Mobile stand for Display	(50-inch model) TY-ST50PB2 (65-inch model) TY-ST65PB2 (80-inch model) TY-ST80LF70
• Wall-hanging bracket (vertical)	(50-inch model) TY-WK42PV20 (80-inch model) TY-WK70PV50*2
• Wall-hanging bracket (angled)	(50-inch model) TY-WK42PR20 (65-inch model) TY-WK65PR20
• Ceiling-hanging bracket	(50-inch model) TY-CE42PS20
• BNC Dual Video Terminal Board	TY-FB9BD*2
• HD-SDI Terminal Board	TY-FB9HD
• HD-SDI Terminal Board with audio	TY-FB10HD
• Dual Link HD-SDI Terminal Board	TY-FB11DHD
• Dual HDMI Terminal Board	TY-FB10HMD*2
• DVI-D Terminal Board	TY-FB11DD
• Digital Interface Box	ET-YFB100G
• DIGITAL LINK Switcher	ET-YFB200G
• This unit does not support long reach communication method of ET-YFB200G.	
• Easy wireless stick	ET-UW100*3
• Early Warning Software	ET-SWA100 series*4

*1: **Precaution for use of TY-ST42P50** (50-inch model)

Use a stand pole "for plasma display (long)" (part number: TBLA3679, TBLA3680).

*2: Discontinued

*3: This product can be purchased in the U.S., Canada, Japan, Australia and New Zealand.

*4: Suffix of the part number may differ depending on the license type.

Note:

- The part number of the optional accessories are subject to change without notice.

When installing the pedestal, read the operating instructions supplied with it carefully and install properly. Also, always use the overturn prevention accessories.

When using a terminal board, read the operating instructions supplied with it carefully and use properly.

Small parts can present choking hazard if accidentally swallowed. Keep small parts away from young children.

Discard unneeded small parts and other objects, including packaging materials and plastic bags/sheets to prevent them from being played with by young children, creating the potential risk of suffocation.

Do not place the Display on sloped or unstable surfaces, and ensure that the Display does not hang over the edge of the base.

- The Display may fall off or tip over.

Install this unit at a location with minimal vibration and which can support the weight of the unit.

- Dropping or falling of the unit may cause injury or malfunction.

Do not place any objects on top of the Display.

- If foreign objects or water get inside the Display, a short-circuit may occur which could result in fire or electric shock. If any foreign objects get inside the Display, please consult your local Panasonic dealer.

Transport only in upright position!

- Transporting the unit with its liquid crystal panel facing upright or downward may cause damage to the internal circuitry.

Ventilation should not be impeded by covering the ventilation openings with items such as newspapers, table cloths and curtains. For sufficient ventilation, see page 10.

When installing the Display vertically, be sure that the Power Indicator comes to the upper side. Heat is generated and it may cause fire or damage to the Display.

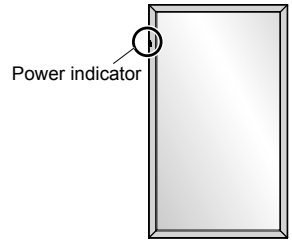

Cautions for Wall or Pedestal Installation

- The installation should be performed by an installation professional. Installing the Display incorrectly may lead to an accident that results in death or serious injury. Use the optional Pedestal. (see page 6)
- Before installation, be sure to check if the mounting location has enough strength to support the weight of the LCD display and the wall hanging bracket for anti drop.
- If you terminate the use of the Display on the Wall or Pedestal, ask a professional to remove the Display as soon as possible.
- When mounting the Display on the wall, prevent the mounting screws and power cable from contacting metal objects inside the wall. An electric shock may occur if they contact metal objects inside the wall.

We are not responsible for any product damage, etc. caused by use of the pedestal, wall-hanging bracket or ceiling-hanging bracket made by other companies, or by failures in the installation environment for the pedestal, wall-hanging bracket or ceiling-hanging bracket even during the warranty period.

Do not install the product to a place where the product is exposed to direct sunlight.

- If the screen is exposed to direct sunlight, the liquid crystal panel may have adverse effect.

■ When using the LCD Display

The Display is designed to operate on 110 - 127 or 220 - 240 V AC, 50/60 Hz.

Do not cover the ventilation holes.

- Doing so may cause the Display to overheat, which can cause fire or damage to the Display.

Do not stick any foreign objects into the Display.

- Do not insert any metal or flammable objects into the ventilations holes or drop them onto the Display, as doing so can cause fire or electric shock.

Do not remove the cover or modify it in any way.

- High voltages which can cause severe electric shocks are present inside the Display. For any inspection, adjustment and repair work, please contact your local Panasonic dealer.

Ensure that the mains plug is easily accessible.

The mains plug shall be connected to a mains socket outlet with a protective earthing connection.

Do not use any power supply cord other than that provided with this unit.

- Doing so may cause short-circuit, generates heat, etc., which could cause electric shock or fire.

Do not use the supplied power supply cord with any other devices.

- Doing so could cause electric shock or fire.

Securely insert the power supply plug as far as it will go.

- If the plug is not fully inserted, heat may be generated which could cause fire. If the plug is damaged or the wall socket is loose, they shall not be used.

Do not handle the power supply plug with wet hands.

- Doing so may cause electric shocks.

Do not do anything that may damage the power cable. When disconnecting the power cable, pull on the plug body, not the cable.

- Do not damage the cable, make any modifications to it, place heavy objects on top of it, heat it, place it near any hot objects, twist it, bend it excessively or pull it. To do so may cause fire and electric shock. If the power cable is damaged, have it repaired at your local Panasonic dealer.

Do not touch the power supply cord or the plug directly by hand when they are damaged.

Electric shock could occur.

Safety Precautions

Do not remove covers and NEVER modify the Display yourself.

- Do not remove the rear cover as live parts are accessible when it is removed. There are no user serviceable parts inside. (High-voltage components may cause serious electrical shock.)
- Have the Display checked, adjusted, or repaired at your local Panasonic dealer.

Keep the pen stand fixing screw and the washer (for 80-inch model only) out of reach of children. If accidentally swallowed, it will be harmful to the body.

- Please contact a doctor immediately in case you doubt that the child may have swallowed it.

If the Display is not going to be used for any prolonged length of time, unplug the power supply plug from the wall outlet.

Picture noise may occur if you connect / disconnect the cables connected to the input terminals you are currently not watching, or if you turn the power of the video equipment on / off, but it is not a malfunction.

To prevent the spread of fire, keep candles or other open flames away from this product at all times.



CAUTION

If problems or malfunction occur, stop using immediately.

■ If problems occur, unplug the power supply plug.

- Smoke or an abnormal odour come out from the unit.
- No picture appears or no sound is heard, occasionally.
- Liquid such as water or foreign objects got inside the unit.
- The unit has deformed or broken parts.

If you continue to use the unit in this condition, it could result in fire or electric shock.

- Turn the power off immediately, unplug the power supply plug from the wall outlet, and then contact the dealer for repairs.
- To cut off the power supply to this Display completely, you need to unplug the power supply plug from the wall outlet.
- Repairing the unit yourself is dangerous, and shall never be done.
- To enable to unplug the power supply plug immediately, use the wall outlet which you can reach easily.

■ Do not touch the unit directly by hand when it is damaged.

Electric shock could occur.

■ When using the LCD Display

Do not bring your hands, face or objects close to the ventilation holes of the Display.

- Heated air comes out from the ventilation holes at the top of Display will be hot. Do not bring your hands or face, or objects which cannot withstand heat, close to this port, otherwise burns or deformation could result.

Required number of people to carry or unpack this unit:

80-inch model 65-inch model : 4 or more people

50-inch model : 2 or more people

- If this is not observed, the unit may drop, resulting in injury.

Be sure to disconnect all cables before moving the Display.

- If the Display is moved while some of the cables are still connected, the cables may become damaged, and fire or electric shock could result.

Disconnect the power supply plug from the wall socket as a safety precaution before carrying out any cleaning.

- Electric shocks can result if this is not done.

Clean the power cable regularly to prevent it becoming dusty.

- If dust built up on the power cord plug, the resultant humidity can damage the insulation, which could result in fire. Pull the power cord plug out from the wall outlet and wipe the mains lead with a dry cloth.

Do not step on, or hang from the display or the Pedestal.

- They might tip over, or might be broken and it may result in injury. Pay special attention to the children.

Do not reverse the polarity (+ and -) of the battery when inserting.

- Mishandling the battery may cause its explosion or leakage, resulting in fire, injury or damage to surrounding properties.
- Insert the battery correctly as instructed. (see page 16)

Remove the batteries from the remote control transmitter when not using for a long period of time.

- The battery may leak, heat, ignite or burst, resulting in fire or damage to surrounding properties.

Do not burn or breakup batteries.

- Batteries must not be exposed to excessive heat such as sunshine, fire or the like.

Do not turn the Display upside down.

Do not position the unit with its display panel facing upright.

Precautions for use

Cautions when installing

Do not set up the Display outdoors.

- The Display is designed for indoor use.

Environmental temperature to use this unit

- When using the unit where it is below 1 400 m (4 593 ft) above sea level: 0 °C to 40 °C (32 °F to 104 °F)
- When using the unit at high altitudes (1 400 m (4 593 ft) and higher and below 2 800 m (9 186 ft) above sea level): 0 °C to 35 °C (32 °F to 95 °F)

Do not install the unit where it is 2 800 m (9 186 ft) and higher above sea level.

- Failure to do so may shorten the life of the internal parts and result in malfunctions.

Required space for ventilation

When using the pedestal (optional accessory), leave a space of 10 cm (3 15/16") or more at the top, left and right, and 7 cm (2 3/4") or more at the rear, and also keep the space between the bottom of the display and the floor surface.

If using some other setting-up method (wall-hanging, etc.), follow the manual of it. (If there is no specific indication of installation dimension in the installation manual, leave a space of 10 cm (3 15/16") or more at the top, bottom, left and right, and 7 cm (2 3/4") or more at the rear.)

Minimum distance:

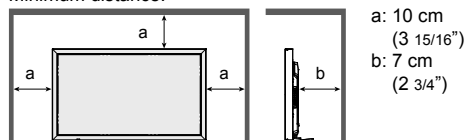

Depending on the temperature or humidity conditions, uneven brightness may be observed. This is not a malfunction.

- This unevenness will disappear while applying current continuously. If not, consult the distributor.

Request Regarding Security

When using this product, take safety measures against the following incidents.

- Personal information being leaked via this product
- Unauthorized operation of this product by a malicious third party
- Interfering or stopping of this product by a malicious third party

Take sufficient security measures.

- Set a password for the LAN control and restrict the users who can log in.
- Make your password difficult to guess as much as possible.
- Change your password periodically.
- Panasonic Corporation or its affiliate companies will never ask for your password directly. Do not divulge your password in case you receive such inquiries.
- The connecting network must be secured by a firewall, etc.
- When disposing the product, initialize the data before disposing. "Shipping"

About Wireless LANs

- The advantage of a wireless LAN is that information can be exchanged between a PC or other such equipment and an access point using radio waves as long as you are within range for radio transmissions. On the other hand, because the radio waves can travel through obstacles (such as walls) and are available everywhere within a given range, problems of the type listed below may occur if security-related settings are not made.
 - A malicious third-party may intentionally intercept and monitor transmitted data including the content of e-mail and personal information such as your ID, password, and/or credit card numbers.
 - A malicious third-party may access your personal or corporate network without authorization and engage in the following types of behaviour. Retrieve personal and/or secret information (information leak)
 - Spread false information by impersonating a particular person (spoofing)
 - Overwrite intercepted communications and issue false data (tampering)
 - Spread harmful software such as a computer virus and crash your data and/or system (system crash)
- Since most wireless LAN adapters or access points are equipped with security features to take care of these problems, you can reduce the possibility of these problems occurring when using this product by making the appropriate security settings for the wireless LAN device.

- Some wireless LAN devices may not be set for security immediately after purchase. To decrease the possibility of occurrence of security problems, before using any wireless LAN devices, be absolutely sure to make all security-related settings according to the instructions given in the operation manuals supplied with them.
Depending on the specifications of the wireless LAN, a malicious third-party may be able to break security settings by special means.
Please contact Panasonic if you need help taking care of security settings or other such.
If you cannot perform security settings for your wireless LAN by yourself, please contact the Panasonic Support Center.
- Panasonic asks customers to thoroughly understand the risk of using this product without making security settings, and recommends that the customer make security settings at their own discretion and responsibility.

About built-in wireless LAN

CAUTION:

Be aware of the following limits before using the Wireless LAN Module.

- To use the Wireless LAN Module, an access point needs to be obtained.
- Do not use the Wireless LAN Module to connect to any wireless network (SSID*) for which you do not have usage rights. Such networks may be listed as a result of searches. However, using them may be regarded as illegal access.

*SSID is a name for identifying a particular wireless network for transmission.

- Do not subject the Wireless LAN Module to high temperatures, direct sunlight or moisture.
- Do not bend, or subject the Wireless LAN Module to strong impacts.
- Do not disassemble or alter the Wireless LAN Module in any way.
- Do not attempt to install the Wireless LAN Module in any incompatible device.
- Do not remove the Wireless LAN Module from the host product during operations.
- Data transmitted and received over radio waves may be intercepted and monitored.
- To avoid malfunctions caused by radio wave interface, keep the host product away from the devices such as other wireless LAN devices, microwaves and the devices that use 2.4 GHz and 5 GHz signals when using the Wireless LAN Module.
- When noises occur due to the static electricity, etc., the host product might stop operating for the protection of the devices. In this case, turn the host product Off with Mains power On / Off switch, then turn it On again.
- Depending on the area, this Wireless LAN Module may not be available.

Notes on Using Wireless Connection

Wireless connection function of the Display uses radio waves in the 2.4 GHz and 5 GHz bands.

A radio station license is not required, but be sure to read and fully understand the following items before use.

Do not use near other wireless equipment.

- The following equipment may use radio waves in the same band as the Display. When the Display is used near these devices, radio wave interference may make communication impossible, or the communication speed may become slower.
 - Microwave ovens, etc.
 - Industrial, chemical and medical equipment, etc.
 - In-plant radio stations for identifying moving objects such as those used in factory manufacturing lines, etc.
 - Designated low-power radio stations

If at all possible, avoid the use of cellular phones, TV sets or radios near the Display.

- Cellular phones, TV sets, radios and similar devices use different radio bands from the Display, so there is no effect on wireless communication or the transmission and reception of these devices. However, radio waves from the Display may produce audio or video noise.

Wireless communication radio waves cannot penetrate steel reinforcements, metal, concrete, etc.

- Communication is possible through walls and floors made from materials such as wood and glass (except glass containing wire mesh), but not through walls and floors made from steel reinforcements, metal, concrete, etc.

Avoid using the Display in locations prone to static electricity.

- If the Display is used in a location prone to static electricity, such as on a carpet, the wireless LAN or wired LAN connection may be lost.
- If this happens, eliminate the source of static electricity or electromagnetic noise and reconnect to the wireless LAN or wired LAN.

Using the Display outside the country

- It is forbidden to take the Display outside the country or region where you purchased it, so use it only in the said country or region. Also, note that depending on countries or regions there are restrictions on the channels and frequencies at which you can use the wireless LAN.

Precautions for use

Available wireless LAN channels

The channels (frequency range) that can be used differ according to the country or region and the connecting method of the wireless LAN. Refer to the table below.

For MIRRORING mode

(When the connecting method is "MIRRORING")

Country or region	Standard	Channels used	Frequency band (Center frequency)
For Europe and CIS	IEEE802.11b/g/n	1 - 11	2.412 GHz - 2.462 GHz
	IEEE802.11a/n	36 / 40 / 44 / 48	5.180 GHz - 5.240 GHz
The power supplies are below 140 V (Except for Europe and CIS)	IEEE802.11b/g/n	1 - 11	2.412 GHz - 2.462 GHz
	IEEE802.11a/n	36 / 40 / 44 / 48 149 / 153 / 157 / 161	5.180 GHz - 5.240 GHz 5.745 GHz - 5.825 GHz
The power supplies are above 190 V (Except for Europe and CIS)	IEEE802.11b/g/n	1 - 11	2.412 GHz - 2.462 GHz

For M-DIRECT mode

(When the connecting method is "M-DIRECT" of "Panasonic APPLICATION")

Country or region	Standard	Channels used	Frequency band (Center frequency)
For Europe and CIS	IEEE802.11b/g/n	1 - 13	2.412 GHz - 2.472 GHz
The power supplies are below 140 V (Except for Europe and CIS)	IEEE802.11b/g/n	1 - 11	2.412 GHz - 2.462 GHz
	IEEE802.11a/n	36 / 40 / 44 / 48 149 / 153 / 157 / 161 / 165	5.180 GHz - 5.240 GHz 5.745 GHz - 5.825 GHz
The power supplies are above 190 V (Except for Europe and CIS)	IEEE802.11b/g/n	1 - 13	2.412 GHz - 2.472 GHz

For USER mode

(When the connecting method is "USER1"/"USER2"/"USER3" of "Panasonic APPLICATION")

Country or region	Standard	Channels used	Frequency band (Center frequency)	Scanning type
For Europe and CIS	IEEE802.11b/g/n	1 - 13	2.412 GHz - 2.472 GHz	Active scanning
		36 / 40 / 44 / 48	5.180 GHz - 5.240 GHz	Active scanning
	IEEE802.11a/n	52 / 56 / 60 / 64 100 / 104 / 108 / 112 / 116 / 120 / 124 / 128 / 132 / 136 / 140	5.260 GHz - 5.320 GHz 5.500 GHz - 5.700 GHz	Passive scanning Passive scanning
The power supplies are below 140 V (Except for Europe and CIS)	IEEE802.11b/g/n	1 - 11	2.412 GHz - 2.462 GHz	Active scanning
		36 / 40 / 44 / 48	5.180 GHz - 5.240 GHz	Active scanning
	IEEE802.11a/n	52 / 56 / 60 / 64	5.260 GHz - 5.320 GHz	Passive scanning
		100 / 104 / 108 / 112 / 116 / 120 / 124 / 128 / 132 / 136 / 140	5.500 GHz - 5.700 GHz	Passive scanning
		149 / 153 / 157 / 161 / 165	5.745 GHz - 5.825 GHz	Active scanning
The power supplies are above 190 V (Except for Europe and CIS)	IEEE802.11b/g/n	1 - 13	2.412 GHz - 2.472 GHz	Passive scanning
	IEEE802.11a/n	149 / 153 / 157 / 161	5.745 GHz - 5.805 GHz	Passive scanning

* The frequency and channel differ depending on the country.

* The passive scanning is performed by changing radio to the channel being scanned in each country.

* Please use the wireless LAN feature in compliance with the laws of each country.

■ For North America

This device is restricted to indoor use when operated in the 5.15 to 5.25 GHz frequency range (Channels 36 to 48).

■ For EU

This device is restricted to indoor use when operated in the 5.15 to 5.35 GHz frequency range (Channels 36 to 64).

■ For Mexico

Operation of this equipment is subject to the following two conditions:

- (1) this equipment might not have a harmful interference and
- (2) this equipment must accept any interference, including one that might cause it to malfunction

■ For Jamaica

- This product contains Type Approved Modules by Jamaica.

Declaration of Conformity (DoC)

"Hereby, Panasonic Corporation declares that this Display is in compliance with the essential requirements and other relevant provisions of the Directive 2014/53/EU."

If you want to get a copy of the original DoC of this Display, please visit the following website:
<http://www.ptc.panasonic.de>

Authorized Representative:

Panasonic Testing Centre

Panasonic Marketing Europe GmbH

Winsbergring 15, 22525 Hamburg, Germany

Indoor use restrictions are to be followed for the following countries if using 5 GHz frequency band.

Austria, Belgium, Bulgaria, Croatia, Cyprus, Czech Republic, Denmark, Estonia, Finland, France, Germany, Greece, Hungary, Iceland, Ireland, Italy, Latvia, Liechtenstein, Lithuania, Luxembourg, Malta, Netherlands, Norway, Poland, Portugal, Romania, Slovakia, Slovenia, Spain, Sweden, Switzerland, Turkey, United Kingdom

WLAN: Maximum Power

20 dBm (2.412 GHz - 2.472 GHz)

23 dBm (5.180 GHz - 5.700 GHz)

Directive: 2014/53/EU

UAE

UAE-TRA

REGISTERED No:

ER0081229/12

DEALER No:

DA0052708/10

Singapore

Complies with
IDA Standards
DB01017

Thailand

"เครื่องโทรคมนาคมและอุปกรณ์นี้มีความสอดคล้องตาม
มาตรฐานทางเทคนิค เลขที่ กทท. มท. 1012-2551"

Notes on Using Wired LAN

When setting up the Display at a place, where electric static occurs often, take a sufficient antistatic measure before start using.

- When the Display is used at a location, where static electricity occurs often, such as on a carpet, a wired LAN communication is disconnected more often. In that case, remove static electricity and the noise source that may cause problems with an antistatic mat, and re-connect the wired LAN.
- In rare cases, the LAN connection is disabled due to static electricity or noise. In that case, turn off the power of the Display and the connected devices once and then re-turn on the power.

The Display may not work properly due to strong radio wave from the broadcast station or the radio.

- If there is any facility or equipment, which outputs strong radio wave, near the installation location, set up the Display at a location sufficiently far from the source of the radio wave. Or, wrap the LAN cable connected to the DIGITAL LINK/LAN terminal by using a piece of metal foil or a metal pipe, of which is grounded at both ends.

Precautions for use

Cleaning and maintenance

The front of the liquid crystal panel has been specially treated. Wipe the surface of the liquid crystal panel gently using only a cleaning cloth or a soft, lint-free cloth.

- If the surface is particularly dirty, wipe with a soft, lint-free cloth which has been soaked in pure water or water in which neutral detergent has been diluted 100 times, and then wipe it evenly with a dry cloth of the same type until the surface is dry.

Wipe off dirt on the IR transmission part with soft cloth.

- Wipe off dirt on the IR transmission part with soft cloth once a day.
If malfunction is due to dirt on the IR transmission part, simply wiping it off lightly can recover the performance.
If dirt is sticky, wipe it off with cloth wrung out of neutral detergent diluted with water and then wipe the part with dry cloth.
- If the substance such as the material of the supplied pen is stuck on the glass surface, wipe it with a wet cloth.
Note that if a deep scratch is caused by using objects other than the supplied pen, it may not be wiped off.
- Do not scratch or hit the surface of the panel with fingernails or other hard objects, otherwise the surface may become damaged. Furthermore, avoid contact with volatile substances such as insect sprays, solvents and thinner, otherwise the quality of the surface may be adversely affected.

If the cabinet becomes dirty, wipe it with a soft, dry cloth.

- If the cabinet is particularly dirty, soak the cloth in water to which a small amount of neutral detergent has been added and then wring the cloth dry. Use this cloth to wipe the cabinet, and then wipe it dry with a dry cloth.
- Do not allow any detergent to come into direct contact with the surface of the Display. If water droplets get inside the unit, operating problems may result.
- Avoid contact with volatile substances such as insect sprays, solvents and thinner, otherwise the quality of the cabinet surface may be adversely affected or the coating may peel off. Furthermore, do not leave it for long periods in contact with articles made from rubber or PVC.

Usage of a chemical cloth

- Do not use a chemical cloth for the panel surface.
- Follow the instructions for the chemical cloth to use it for the cabinet.

Touch panel

Carefully observe the following instructions as the display has an optical touch panel.

Do not expose the display to direct sunlight or strong light source during use.

- Otherwise malfunction may occur since the optical touch panel of the display uses infrared rays.

After turning on the power of the display, do not touch the IR transmission part and the screen until any image is displayed.

- Otherwise the touched part may be detected as defective elements, resulting in abnormal operation. If this occurred, turn the display off and then on.

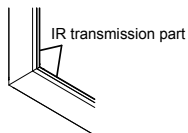

Always use a finger or the supplied pen to operate the touch panel. Do not use a hard or sharp tip such as nail, ball-point pen, and pencil.

When using any other infrared device, keep a distance to prevent erroneous operation.

Disposal

When disposing the product, ask your local authority or dealer about the correct methods of disposal.

For USA-California Only

This product contains a CR Coin Cell Lithium Battery which contains Perchlorate Material - special handling may apply.
See www.dtsc.ca.gov/hazardouswaste/perchlorate

Accessories

Accessories Supply

Check that you have the accessories and items shown

Software CD-ROM × 1

TH-80BF1U, TH-65BF1U, TH-50BF1U:
DPQC1006ZB
TH-80BF1E, TH-65BF1E, TH-50BF1E:
DPQC1005ZB
TH-80BF1W, TH-65BF1W, TH-50BF1W:
DPQC1007ZC



Remote Control
Transmitter
N2QAYB000691



Batteries for the Remote
Control Transmitter
(R6 (UM3) Size × 2)

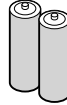

Clamper × 1
TMME289

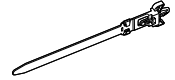

Pen
TKR5ZA45001

80-inch model × 4
65-inch model 50-inch model × 2

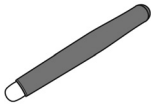

Eraser × 1
TKK5ZH50031

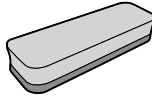

Pen Stand × 1
TKK5ZA50021
(see page 17)

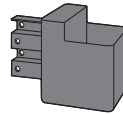

Washer × 2
(see page 18)
80-inch model
TMM5ZX010



Screw × 2

80-inch model XYN4+F12FJK
65-inch model 50-inch model XYN4+F8FJK
(see page 17)



USB cable × 1
K1HY05Y0189

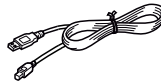

Power supply cord

TH-80BF1U
TH-65BF1U
TH-50BF1U

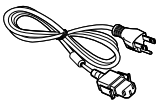

TXFMX011WFU

TH-80BF1E
TH-65BF1E
TH-50BF1E

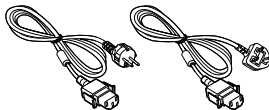

TXFMX011TFR

TXFMX021TFR

TH-80BF1W
TH-65BF1W
TH-50BF1W

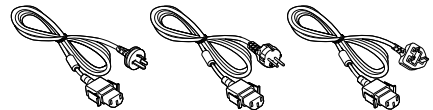

TXFMX011NGW

TXFMX011TFR

TXFMX021TFR



TXFMX01YGfZ

Attention

- Store small parts in an appropriate manner, and keep them away from young children.
- The part numbers of accessories are subject to change without notice. (The actual part number may differ from the ones shown above.)
- In case you lost accessories, please purchase them from your dealer. (Available from the customer service)
- Dispose the packaging materials appropriately after taking out the items.

Contents in the CD-ROM

The contents below are included in the supplied CD-ROM.

Instruction (PDF)	Operating Instructions - Display Operations	
	Operating Instructions - Network Operations	
	Operating Instructions - Wireless Manager ME	
	Software license	GNU GENERAL PUBLIC LICENSE GNU LESSER GENERAL PUBLIC LICENSE
Software	WhiteBoard Software (Windows)	Allows the display to be used as whiteboard. You can run the software directly from external storage without installing it in your computer.
	Wireless Manager ME (Windows/Mac)	Allows the image on the computer screen to be sent wirelessly or via wired LAN. Switch the input to Panasonic APPLICATION before use. For more details, see the instruction manual of Wireless Manager ME.

Remote Control Batteries

Requires two R6 batteries.

1. Pull and hold the hook, then open the battery cover.
2. Insert batteries - note correct polarity (+ and -).
3. Replace the cover.

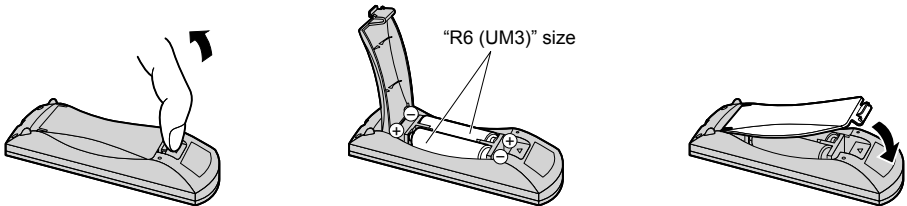

Helpful Hint:

For frequent remote control users, replace old batteries with Alkaline batteries for longer life.

⚠️ Precaution on battery use

Incorrect installation can cause battery leakage and corrosion that will damage the remote control transmitter. Disposal of batteries should be in an environment-friendly manner.

Observe the following precaution:

1. Batteries shall always be replaced as a pair. Always use new batteries when replacing the old set.
2. Do not combine a used battery with a new one.
3. Do not mix battery types (example: "Zinc Carbon" with "Alkaline").
4. Do not attempt to charge, short-circuit, disassemble, heat or burn used batteries.
5. Battery replacement is necessary when remote control acts sporadically or stops operating the Display set.
6. Do not burn or breakup batteries.
7. Batteries must not be exposed to excessive heat such as sunshine, fire or the like.

Mounting Pen Stand

50-inch model

65-inch model

Mounting position of the Pen Stand

50-inch model

The supplied Pen Stand can be mounted in one of the four dedicated screw hole positions on the back of the Display.

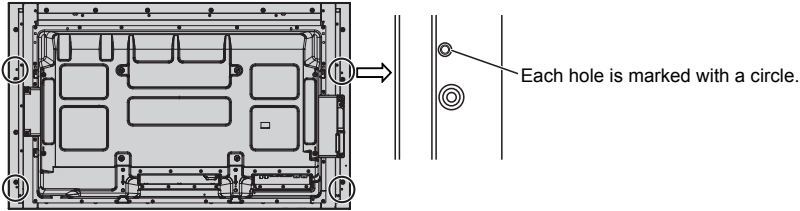

65-inch model

The supplied Pen Stand can be mounted in one of the nine positions on the back of the Display. Remove one screw fixing the back cover and mount the Pen Stand.

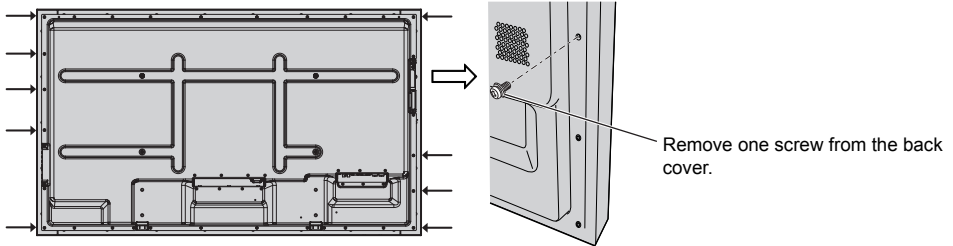

Mounting

Mount the Pen Stand using one supplied screw.

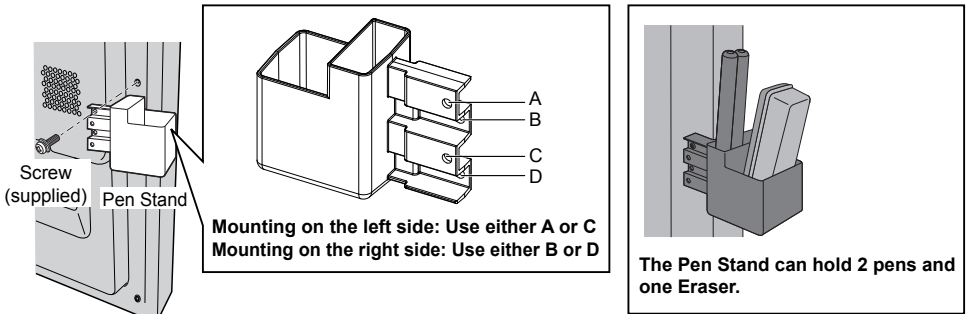

Accessories

80-inch model

The supplied Pen Stand can be mounted on one of the nine positions on the back of the Display.

1 Remove a screw from the back cover.

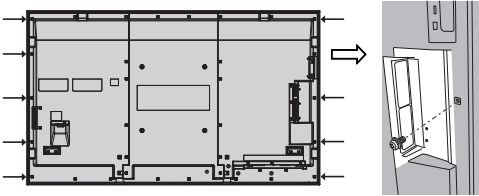

2 Peel the paper backing off the supplied washer.

3 Paste the washer to a screw hole for the pen stand.

Any of the hole A to D can be used to fix the pen stand.

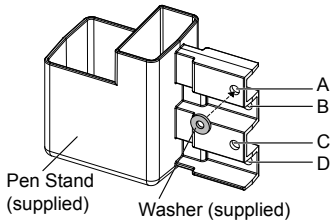

4 Mount the Pen Stand with the supplied screw.

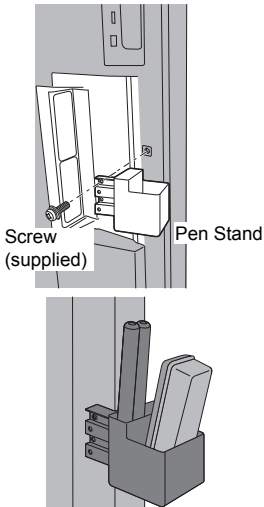

The Pen Stand can hold 2 pens and one Eraser.

Connections

AC cord connection and fixing, cable fixing

50-inch model

65-inch model

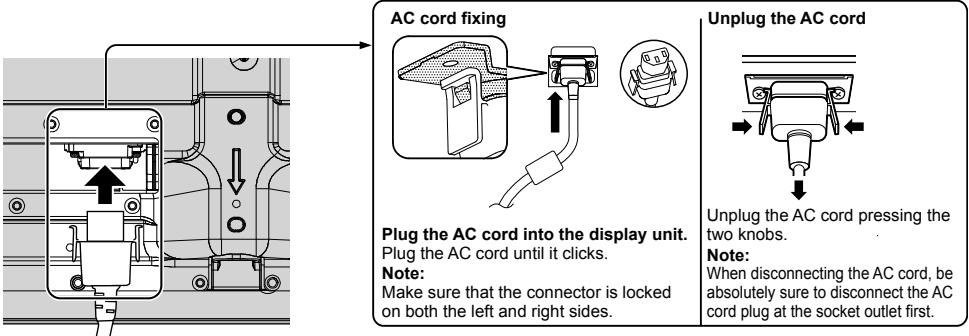

AC cord fixing

Plug the AC cord into the display unit. Plug the AC cord until it clicks.

Note:
Make sure that the connector is locked on both the left and right sides.

Unplug the AC cord

Unplug the AC cord pressing the two knobs.

Note:
When disconnecting the AC cord, be absolutely sure to disconnect the AC cord plug at the socket outlet first.

When using the Wall-hanging bracket (vertical) 50-inch model

Note:

When using the Wall-hanging bracket (vertical) (TY-WK42PV20), use the holes (A) and (B) to secure the cables. If the clammer is used on the hole (C), the cables may be caught by the wall-hanging bracket.

50-inch model

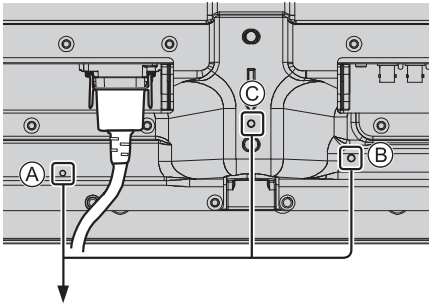

65-inch model

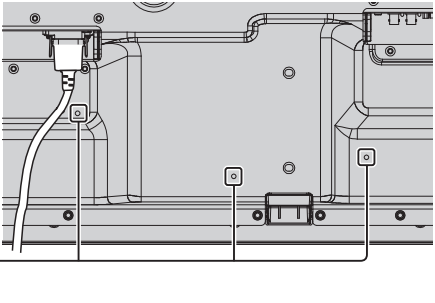

Using the clammer

Secure any excess cables with clammer as required.

Note:

One clammer is supplied with this unit. In case of securing cables at three positions, please purchase it separately. If you need more clamppers, purchase them from your dealer. (Available from the customer service)

1 Attach the clammer

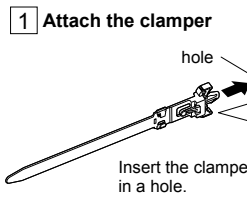

hole

Insert the clammer in a hole.

To remove from the unit:

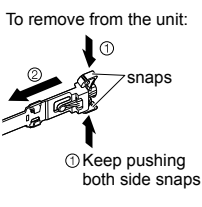

snaps

① Keep pushing both side snaps

2 Bundle the cables

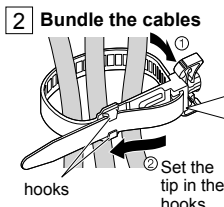

hooks

② Set the tip in the hooks

To loosen:

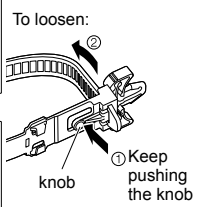

knob

① Keep pushing the knob

80-inch model

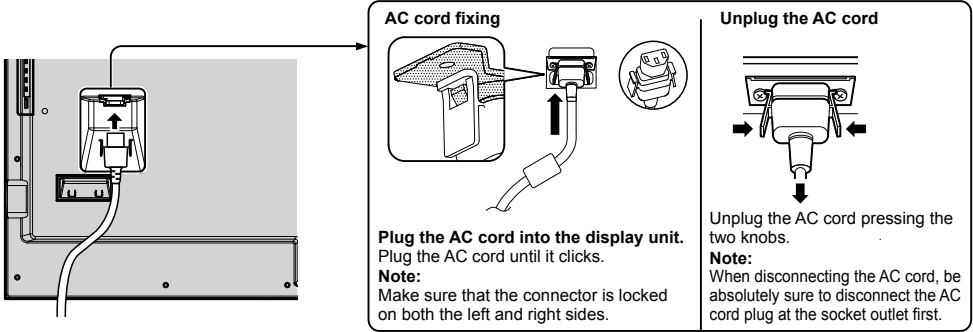

AC cord fixing
Plug the AC cord into the display unit. Plug the AC cord until it clicks.
Note: Make sure that the connector is locked on both the left and right sides.

Unplug the AC cord
Unplug the AC cord pressing the two knobs.
Note: When disconnecting the AC cord, be absolutely sure to disconnect the AC cord plug at the socket outlet first.

Using the clamper

Secure any excess cables with clamper as required.

Note:

One clamper is supplied with this unit. In case of securing cables at four positions, please purchase it separately. If you need more clampers, purchase them from your dealer. (Available from the customer service)

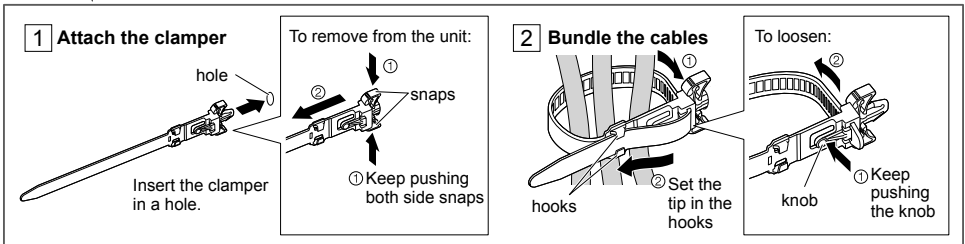
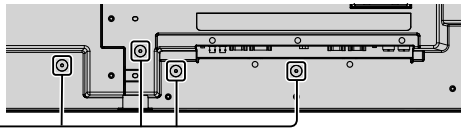

1 Attach the clamper
hole
Insert the clamper in a hole.
To remove from the unit:
① snaps
① Keep pushing both side snaps

2 Bundle the cables
hooks
Set the tip in the hooks
To loosen:
① Keep pushing the knob
② knob

Video equipment connection

50-inch model 65-inch model

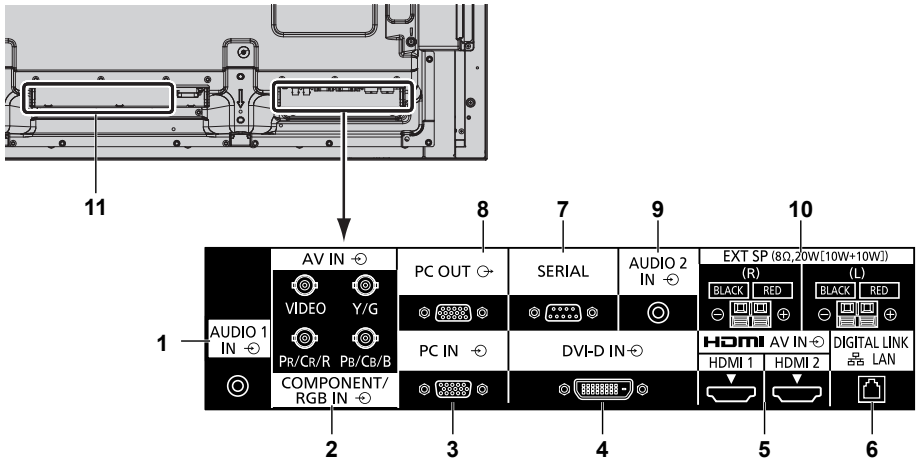

1 AUDIO 1 IN : **Audio Input Terminal shared with COMPONENT/RGB IN and VIDEO IN**

2 COMPONENT/RGB/VIDEO IN : **COMPONENT / RGB Video Input Terminal (P_R/C_R/R, P_B/C_B/B, Y/G)**
Connect to video equipment with "YP_BP_R / YC_BC_R" or "RGB" output.

AV IN : **Composite Video Input Terminal (VIDEO)**
Connect to video equipment with Composite signal output.

3 PC IN : **PC Input Terminal**
Connect to video terminal of PC, video equipment with "YP_BP_R / YC_BC_R" or "RGB" output.

4 DVI-D IN : **DVI-D Input Terminal**
Connect to video equipment with DVI-D output.

5 AV IN (HDMI 1, HDMI 2) : **HDMI Input Terminal**
Connect to video equipment such as VCR or DVD player, etc.

6 DIGITAL LINK / DIGITAL LINK Input Terminal LAN :
Control the Display by connecting to Network. Alternatively, connect to a device that sends video and audio signals via the DIGITAL LINK terminal.

7 SERIAL : **SERIAL Input Terminal**
Control the Display by connecting to PC.

8 PC OUT : **Monitor Out Terminal**
Video signals being reproduced on the display are reproduced on another sub monitor as PC video signals.

9 AUDIO 2 IN : **Audio input terminal shared with DVI-D IN and PC IN**

10 EXT SP : **Speaker Terminal**
Connect to external speaker.

11 SLOT : **Expansion slot**
(see page 6)

Note: The right side slot is for terminal board with 2-slot width. The terminal board with 1-slot width does not function when installed in the right side slot.

80-inch model

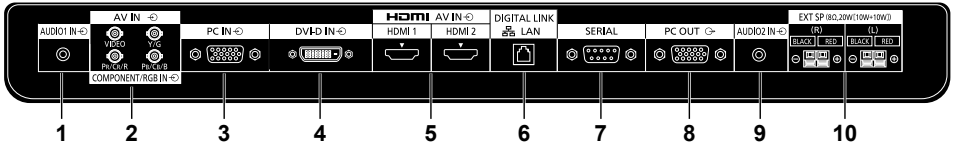
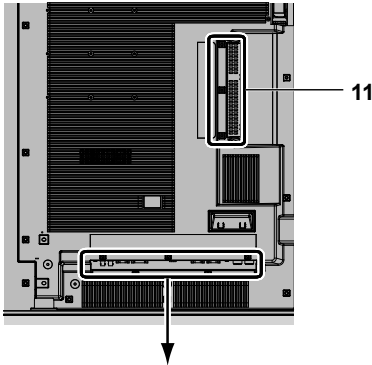

- 1 **AUDIO 1 IN :** **Audio Input Terminal shared with COMPONENT/RGB IN and VIDEO IN**

- 2 **COMPONENT/RGB/VIDEO IN :** **COMPONENT / RGB Video Input Terminal (P_R/C_R/R, P_B/C_B/B, Y/G)**
Connect to video equipment with "YP_BP_R / YC_BC_R" or "RGB" output.

- AV IN :** **Composite Video Input Terminal (VIDEO)**
Connect to video equipment with Composite signal output.

- 3 **PC IN :** **PC Input Terminal**
Connect to video terminal of PC, video equipment with "YP_BP_R / YC_BC_R" or "RGB" output.

- 4 **DVI-D IN :** **DVI-D Input Terminal**
Connect to video equipment with DVI-D output.

- 5 **AV IN (HDMI 1, HDMI 2) :** **HDMI Input Terminal**
Connect to video equipment such as VCR or DVD player, etc.

- 6 **DIGITAL LINK / LAN :** **DIGITAL LINK Input Terminal**
Control the Display by connecting to Network. Alternatively, connect to a device that sends video and audio signals via the DIGITAL LINK terminal.

 - 7 **SERIAL :** **SERIAL Input Terminal**
Control the Display by connecting to PC.

 - 8 **PC OUT :** **Monitor Out Terminal**
Video signals being reproduced on the display are output to another sub monitor as PC video signals.

 - 9 **AUDIO 2 IN :** **Audio input terminal shared with DVI-D IN and PC IN**

 - 10 **EXT SP :** **Speaker Terminal**
Connect to external speaker.

 - 11 **SLOT :** **Expansion slot**
(see page 6)
- Note:** The upper side slot is for terminal board with 2-slot width. The terminal board with 1-slot width does not function when installed in the upper side slot.

Before connecting

- Before connecting cables, carefully read the operating instructions for the external device to be connected.
- Turn off the power of all devices before connecting cables.
- Take note of the following points before connecting the cables. Failure to do so may result in malfunctions.
 - When connecting a cable to the unit or a device connected to the unit itself, touch any nearby metallic objects to eliminate static electricity from your body before performing work.
 - Do not use unnecessarily long cables to connect a device to the unit or to the unit body. The longer the cable, the more susceptible to noise it becomes. Since using a cable while it is wound makes it act like an antenna, it is more susceptible to noise.
 - When connecting cables, connect GND first, then insert the connecting terminal of the connecting device in a straight manner.
- Acquire any connection cable necessary to connect the external device to the system that is neither supplied with the device nor available as an option.
- If the outer shape of the plug of a connection cable is large, it may come in contact with the periphery such as a back cover or the plug of an adjacent connection cable. Use a connection cable with the suitable plug size for the terminal alignment.
- If video signals from video equipment contain too much jitter, the images on the screen may wobble. In this case, a time base corrector (TBC) must be connected.
- When the sync signals output from PC or video equipment are disturbed, for example, when changing settings of video output, the colour of the video may be disturbed temporarily.
- The unit accepts Composite video signals, YCBCR/YPBPR signals, analogue RGB signals and digital signals.
- Some PC models are not compatible with the unit.
- Use cable compensator when you connect devices to the unit using long cables. Otherwise the image may not display properly.

Power On / Off

Connecting the AC cord plug to the Display.

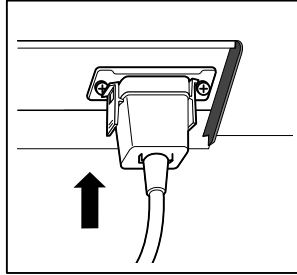
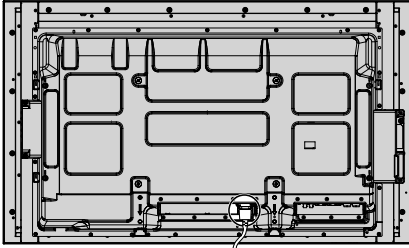

Connecting the plug to the Wall Outlet

Notes:

- Main plug types vary between countries. The power plug shown at right may, therefore, not be the type fitted to your set.
- When disconnecting the AC cord, be absolutely sure to disconnect the AC cord plug at the socket outlet first.

Press the Power switch on the Display to turn the set on: Power-On.

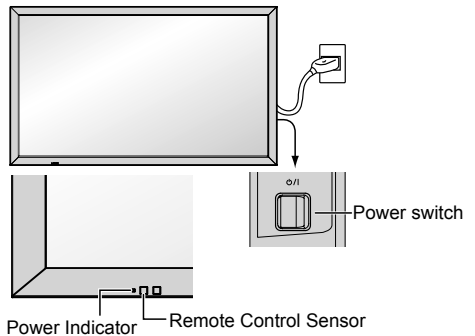

Power Indicator: Blue

[Starting up the touch screen and network]

It takes some time for the touch screen and network to start up just after the power is turned on. During that time, "Touch screen settings", "Network settings" in the "Setup" menu is grayed out and cannot be set.



Press the  button on the remote control to turn the Display off.

Power Indicator: Orange or purple

Press the  button on the remote control to turn the Display on.

Power Indicator: Blue

Turn the power to the Display off by pressing the  switch on the unit, when the Display is on or in standby mode.

Notes:

- Operate pointing the remote control directly at the unit's Remote Control Sensor.
- During operation of the power management function, the power indicator turns purple in the power off state.



When first switching on the unit

Following screen will be displayed when the unit is turned on for the first time.

Use the remote control to make the settings. Pressing the buttons on the main unit or multi-touch operation will not work.

OSD language

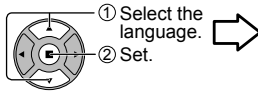

Day/Time settings

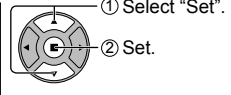
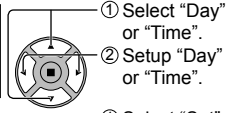
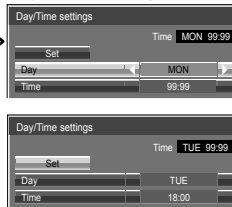

Notes:

- Once the items are set, the screens won't be displayed when switching on the unit next time.
- After the setting, the items can be changed in the following menus.
OSD language
Day/Time settings

Power ON message

The following message may be displayed when turning the unit power ON:

WhiteBoard Startup screen

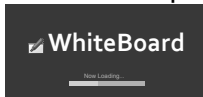

When the power is turned ON with the Input switch of the WHITEBOARD, the built-in WhiteBoard starts up.

Also, the following startup screens are displayed depending on the input.

MIRRORING

MEMORY VIEWER

Touch screen connection status display

When not connected to a computer via USB



Touch operation of the display is possible after this message appears.

When connected to a computer via USB



No activity power off Precautions



If "No activity power off" in Setup menu is set to "Enable", a warning message is displayed every time the power is turned ON.

Power Management Information



If "Power management" is functioned, an information message is displayed every time the power is turned ON.

These message displays can be set with the following menu: Options menu

Power on message (No activity power off)

Power on message (Power management)

COLOR UNIVERSAL DESIGN Information



The information is displayed when "Setup" - "COLOR UNIVERSAL DESIGN" is set to "On".

About COLOR UNIVERSAL DESIGN (CUD)

Color Universal Design is a design made in consideration of colorations to allow information to be accurately conveyed to people who see colour differently from ordinary people (congenital colour weakness, senile cataract, glaucoma, etc.).

Basic Controls

50-inch model

65-inch model

Main Unit

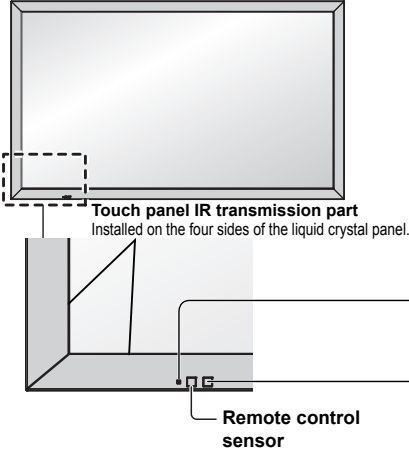

Power Indicator

The Power Indicator will light.

- Power-OFF ...Indicator not illuminated (The unit will still consume some power as long as the power cord is still inserted into the wall outlet.)
- Standby ...
 - Orange
 - Purple (When "Slot power" is set to "On" and Terminal Board is installed.)
 - Purple (Depending on the type of the function board installed, when the power is supplied to the slot.)
 - Purple (When "Network control" is set to "On" or "Wireless network standby" is set to "On". Refer to "Operating Instructions, Network Operations")
 - Purple (When "Quick launch" is set to "On".)
- Power-ON... Blue
- HDMI1 power management
- HDMI2 power management
 - Purple (With HDMI1 or HDMI2 input signal.)
- * These functions are not supported by TH-80BF1E, TH-65BF1E, TH-50BF1E.
- PC power management (DPMS)
 - Purple (With PC input signal.)
- DVI-D power management
 - Purple (With DVI input signal.)

Notes:

- If the power indicator is purple, power consumption during standby is generally larger than that of when the power indicator is orange.
 - Considering COLOR UNIVERSAL DESIGN, purple lights up brighter than blue.
- About COLOR UNIVERSAL DESIGN (CUD) (see page 25)

Brightness Sensor

Detects the brightness in the viewing environment.

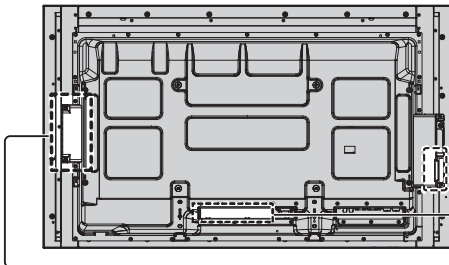

USB (VIEWER): Connect to USB memory.

USB (TOUCH): When using the "WhiteBoard Software" from the supplied CD-ROM, connect the computer via USB cable.

SLOT: Terminal board (optional accessories) insert slot (see page 6)

Note:

The right side slot is for terminal board with 2-slot width. The terminal board with 1-slot width does not function when installed in the right side slot.

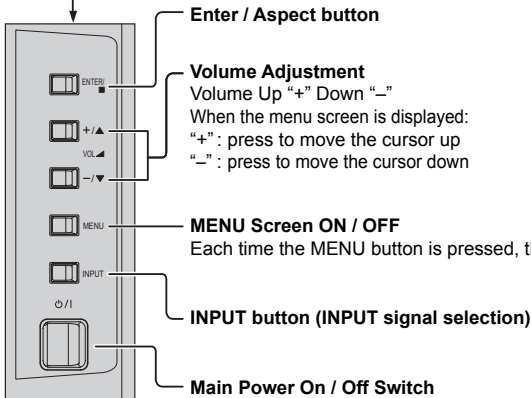

80-inch model

Main Unit

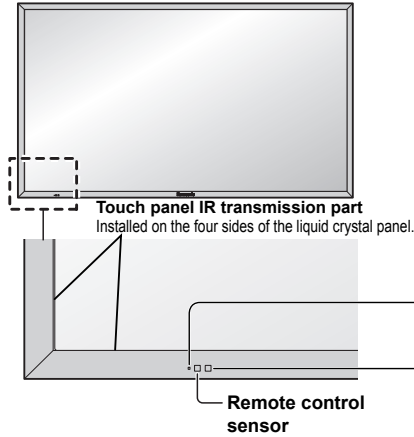

Power Indicator

The Power Indicator will light.

- Power-OFF... Indicator not illuminated (The unit will still consume some power as long as the power cord is still inserted into the wall outlet.)
- Standby Orange
 - Purple (When "Slot power" is set to "On" and Terminal Board is installed.)
 - Purple (Depending on the type of the function board installed, when the power is supplied to the slot.)
 - Purple (When "Network control" is set to "On" or "Wireless network standby" is set to "On". Refer to "Operating Instructions, Network Operations")
 - Purple (When "Quick launch" is set to "On".)
- Power-ON... Blue
- HDMI1 power management
HDMI2 power management
..... Purple (With HDMI1 or HDMI2 input signal.)
- *These functions are not supported by TH-80BF1E, TH-65BF1E, TH-50BF1E.
- PC power management (DPMS)
..... Purple (With PC input signal.)
- DVI-D power management
..... Purple (With DVI input signal.)

Notes:

- If the power indicator is purple, power consumption during standby is generally larger than that of when the power indicator is orange.
- Considering COLOR UNIVERSAL DESIGN, purple lights up brighter than blue.
- About COLOR UNIVERSAL DESIGN (CUD) (see page 25)

Brightness Sensor

Detects the brightness in the viewing environment.

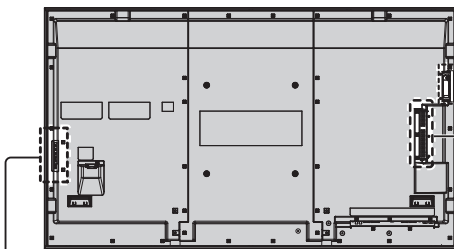

Note:
The upper side slot is for terminal board with 2-slot width. The terminal board with 1-slot width does not function when installed in the upper side slot.

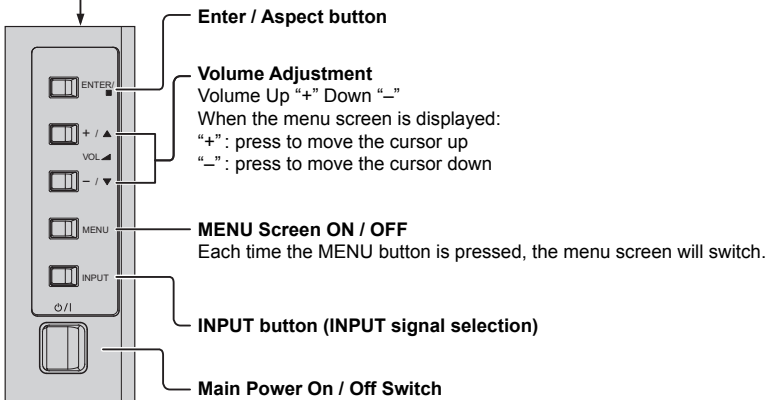

Remote Control Transmitter

ACTION button
Press to make selections.

ASPECT button
Press to adjust the aspect.

Standby (ON / OFF) button
The Display must first be plugged into the wall outlet and turned on at the power switch (see page 24). Press this button to turn the Display On, from Standby mode. Press it again to turn the Display Off to Standby mode.

POS./SIZE button

PICTURE button

Sound mute On / Off
Press this button to mute the sound.
Press again to reactivate sound. Sound is also reactivated when power is turned off or volume level is changed.

N button

POSITION buttons

INPUT button
Press to select Input signal sequentially.

ECO MODE (ECO)
Press to change the ECO MODE setup status.

FUNCTION buttons (FUNCTION)

OFF TIMER button

The Display can be preset to switch to stand-by after a fixed period. The setting changes to 30 minutes, 60 minutes, 90 minutes and 0 minutes (off timer cancelled) each time the button is pressed.

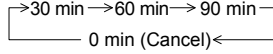

When three minutes remain, "Off timer 3 min" will flash.
The off timer is cancelled if a power interruption occurs.

AUTO SETUP button

Automatically adjusts the position/size of the screen.

SET UP button

SOUND button

Volume Adjustment

Press the Volume Up "+" or Down "-" button to increase or decrease the sound volume level.

R button

Press the R button to return to previous menu screen.

RECALL button

Press the "RECALL" button to display the current system status.

- ① Input label
- ② Aspect mode
- ③ Off timer
- ④ Clock display

The off timer indicator is displayed only when the off timer has been set.

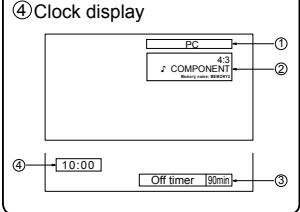

Digital Zoom

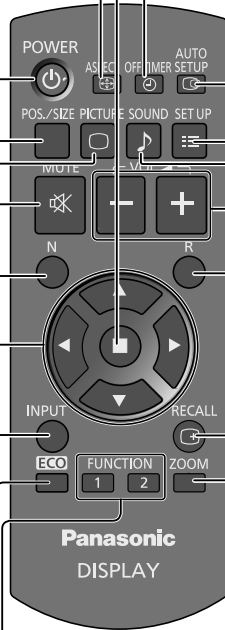

Specifications

	TH-80BF1U	TH-80BF1E / TH-80BF1W
Power Source	110 - 127 V ~ (110 - 127 V alternating current), 50/60Hz	220 - 240 V ~ (220 - 240 V alternating current), 50/60Hz
Power Consumption		
Power on	350 W	350 W
Stand-by condition	0.5 W	0.5 W
Power off condition	0.3 W	0.3 W
LCD Display panel	80-inch VA panel (LED backlight), 16:9 aspect ratio	
Screen size	1,771 mm (W) × 996 mm (H) × 2,032 mm (diagonal) / 69.7" (W) × 39.2" (H) × 80.0" (diagonal)	
(No. of pixels)	2,073,600 (1,920 (Horizontal) × 1,080 (Vertical)) [5,760 × 1,080 dots]	
Operating condition		
Temperature	32 °F - 104 °F (0 °C - 40 °C)	
Humidity	20 % - 80 % (no condensation)	
Applicable signals		
Colour System	NTSC, PAL, PAL60, SECAM, Modified NTSC	
Scanning format	525 (480) / 60i · 60p, 625 (575) / 50i · 50p, 750 (720) / 60p · 50p, 1125 (1080) / 60i · 60p · 50i · 50p · 24p · 25p · 30p · 24psF, 1250 (1080) / 50i	
PC signals	VGA, SVGA, XGA, SXGA UXGA ···· (compressed) Horizontal scanning frequency 15 - 110 kHz Vertical scanning frequency 48 - 120 Hz	
Connection terminals		
AV IN	VIDEO	BNC
AUDIO 1 IN		Stereo mini jack (M3) × 1
HDMI 1		1.0 Vp-p (75 Ω)
HDMI 2		0.5 Vrms, Shared with COMPONENT/RGB IN
COMPONENT/RGB IN		
Y/G	BNC	with sync 1.0 Vp-p (75 Ω)
PB/CB/B	BNC	0.7 Vp-p (75 Ω)
PR/CR/R	BNC	0.7 Vp-p (75 Ω)
AUDIO 1 IN		0.5 Vrms, Shared with VIDEO
DVI-D IN		DVI-D 24 Pin
AUDIO 2 IN		Content Protection
PC IN		Stereo mini jack (M3) × 1
AUDIO 2 IN		High-Density Mini D-sub 15 Pin
SERIAL		External Control Terminal
PC OUT		D-sub 9 Pin
USB (VIEWER)		TYPE A USB connector
USB (TOUCH)		TYPE B USB connector
DIGITAL LINK / LAN		For RJ45 network and DIGITAL LINK connections, compatible with PLink™ Communication method: RJ45 100BASE-TX
EXT SP		8 Ω, 20 W [10 W + 10 W] (10 % THD)
Sound		
Speakers		120 mm × 40 mm × 2 pcs
Audio Output		20 W [10 W + 10 W] (10 % THD)
Dimensions (W × H × D)	1,868 mm × 1,093 mm × 104 mm / 73.6" × 43.1" × 4.1"	
Mass (weight)	approx. 81.0 kg / 178.6 lbs net	

Specifications

	TH-65BF1U	TH-65BF1E / TH-65BF1W
Power Source	110 - 127 V ~ (110 - 127 V alternating current), 50/60Hz	220 - 240 V ~ (220 - 240 V alternating current), 50/60Hz
Power Consumption		
Power on		215 W
Stand-by condition		0.5 W
Power off condition		0.3 W
LCD Display panel	65-inch VA panel (LED backlight), 16:9 aspect ratio	
Screen size	1,428 mm (W) × 803 mm (H) × 1,638 mm (diagonal) / 56.2" (W) × 31.6" (H) × 64.5" (diagonal)	
(No. of pixels)	2,073,600 (1,920 (Horizontal) × 1,080 (Vertical)) [5,760 × 1,080 dots]	
Operating condition		
Temperature	32 °F - 104 °F (0 °C - 40 °C)	
Humidity	20 % - 80 % (no condensation)	
Applicable signals		
Colour System	NTSC, PAL, PAL60, SECAM, Modified NTSC	
Scanning format	525 (480) / 60i · 60p, 625 (575) / 50i · 50p, 750 (720) / 60p · 50p, 1125 (1080) / 60i · 60p · 50i · 50p · 24p · 25p · 30p · 24psF, 1250 (1080) / 50i	
PC signals	VGA, SVGA, XGA, SXGA UXGA ···· (compressed) Horizontal scanning frequency 15 - 110 kHz Vertical scanning frequency 48 - 120 Hz	
Connection terminals		
AV IN	VIDEO	BNC 1.0 Vp-p (75 Ω)
	AUDIO 1 IN	Stereo mini jack (M3) × 1 0.5 Vrms, Shared with COMPONENT/RGB IN
	HDMI 1 HDMI 2	TYPE A Connector × 2
COMPONENT/RGB IN		
	Y/G PB/CB/B PR/CR/R AUDIO 1 IN	BNC with sync 1.0 Vp-p (75 Ω) BNC 0.7 Vp-p (75 Ω) BNC 0.7 Vp-p (75 Ω) Stereo mini jack (M3) × 1 0.5 Vrms, Shared with VIDEO
DVI-D IN		
	AUDIO 2 IN	DVI-D 24 Pin Compliance with DVI Revision 1.0 Content Protection Compatible with HDCP 1.1 Stereo mini jack (M3) × 1 0.5 Vrms, Shared with PC IN
PC IN		High-Density Mini D-sub 15 Pin Y or G with sync 1.0 Vp-p (75 Ω) Y or G without sync 0.7 Vp-p (75 Ω) PB/CB/B: 0.7 Vp-p (75 Ω) PR/CR/R: 0.7 Vp-p (75 Ω) TTL high impedance, positive polarity / negative polarity (automatic) 0.5 Vrms, Shared with DVI-D IN
	AUDIO 2 IN	Stereo mini jack (M3) × 1
SERIAL	External Control Terminal D-sub 9 Pin	RS-232C compatible
PC OUT	R: 0.7 Vp-p (75 Ω) G: 0.7 Vp-p (75 Ω) B: 0.7 Vp-p (75 Ω) HD/VD: 1.0 - 5.0 Vp-p	
USB (VIEWER)	TYPE A USB connector	
USB (TOUCH)	TYPE B USB connector	
DIGITAL LINK / LAN	For RJ45 network and DIGITAL LINK connections, compatible with PLink™ Communication method: RJ45 100BASE-TX	
EXT SP	8 Ω, 20 W [10 W + 10 W] (10 % THD)	
Sound		
Speakers	120 mm × 40 mm × 2 pcs	
Audio Output	20 W [10 W + 10 W] (10 % THD)	
Dimensions (W × H × D)	1,517 mm × 892 mm × 108 mm / 59.8" × 35.2" × 4.3"	
Mass (weight)	approx. 58.0 kg / 127.9 lbs net	

Specifications

	TH-50BF1U	TH-50BF1E / TH-50BF1W
Power Source	110 - 127 V ~ (110 - 127 V alternating current), 50/60Hz	220 - 240 V ~ (220 - 240 V alternating current), 50/60Hz
Power Consumption		
Power on	140 W	
Stand-by condition	0.5 W	
Power off condition	0.3 W	
LCD Display panel	50-inch VA panel (LED backlight), 16:9 aspect ratio	
Screen size	1,095 mm (W) × 616 mm (H) × 1,257 mm (diagonal) / 43.1" (W) × 24.2" (H) × 49.5" (diagonal) /	
(No. of pixels)	2,073,600 (1,920 (Horizontal) × 1,080 (Vertical)) [5,760 × 1,080 dots]	
Operating condition		
Temperature	32 °F - 104 °F (0 °C - 40 °C)	
Humidity	20 % - 80 % (no condensation)	
Applicable signals		
Colour System	NTSC, PAL, PAL60, SECAM, Modified NTSC	
Scanning format	525 (480) / 60i · 60p, 625 (575) / 50i · 50p, 750 (720) / 60p · 50p, 1125 (1080) / 60i · 60p · 50i · 50p · 24p · 25p · 30p · 24psF, 1250 (1080) / 50i	
PC signals	VGA, SVGA, XGA, SXGA UXGA ···· (compressed) Horizontal scanning frequency 15 - 110 kHz Vertical scanning frequency 48 - 120 Hz	
Connection terminals		
AV IN	VIDEO AUDIO 1 IN	BNC Stereo mini jack (M3) × 1 1.0 Vp-p (75 Ω) 0.5 Vrms, Shared with COMPONENT/RGB IN
	HDMI 1 HDMI 2	TYPE A Connector × 2
	COMPONENT/RGB IN	
	Y/G PB/CB/B PR/CR/R AUDIO 1 IN	BNC BNC BNC Stereo mini jack (M3) × 1 with sync 1.0 Vp-p (75 Ω) 0.7 Vp-p (75 Ω) 0.7 Vp-p (75 Ω) 0.5 Vrms, Shared with VIDEO
	DVI-D IN	DVI-D 24 Pin Content Protection Stereo mini jack (M3) × 1 Compliance with DVI Revision 1.0 Compatible with HDCP 1.1 0.5 Vrms, Shared with PC IN
	PC IN	High-Density Mini D-sub 15 Pin Y or G with sync 1.0 Vp-p (75 Ω) Y or G without sync 0.7 Vp-p (75 Ω) PB/CB/B: 0.7 Vp-p (75 Ω) PR/CR/R: 0.7 Vp-p (75 Ω) TTL high impedance, positive polarity / negative polarity (automatic) 0.5 Vrms, Shared with DVI-D IN
	AUDIO 2 IN	Stereo mini jack (M3) × 1
	SERIAL	External Control Terminal D-sub 9 Pin RS-232C compatible
	PC OUT	R: 0.7 Vp-p (75 Ω) G: 0.7 Vp-p (75 Ω) B: 0.7 Vp-p (75 Ω) HD/VD: 1.0 - 5.0 Vp-p
	USB (VIEWER)	TYPE A USB connector
	USB (TOUCH)	TYPE B USB connector
	DIGITAL LINK / LAN	For RJ45 network and DIGITAL LINK connections, compatible with PLink™ Communication method: RJ45 100BASE-TX
	EXT SP	8 Ω, 20 W [10 W + 10 W] (10 % THD)
Sound		
Speakers	120 mm × 40 mm × 2 pcs	
Audio Output	20 W [10 W + 10 W] (10 % THD)	
Dimensions (W × H × D)	1,185 mm × 705 mm × 104 mm / 46.7" × 27.8" × 4.1"	
Mass (weight)	approx. 34.0 kg / 75.0 lbs	

Note:

- Design and specifications are subject to change without notice. Mass and dimensions shown are approximate.

Software License

Software information regarding this product

This product incorporates the following software.

- (1) The software which is developed independently by or for Panasonic Corporation
- (2) The software owned by third party and licensed to Panasonic Corporation
- (3) The software which is licensed under the GNU GENERAL PUBLIC LICENSE Version2.0 (GPL V2.0)
- (4) The software which is licensed under the GNU LESSER GENERAL PUBLIC LICENSE Version2.1 (LGPL V2.1)
- (5) Open source software which is not licensed under the GPL V2.0 and LGPL V2.1

The software categorized as (3) ~ (5), the license is available in accordance with gnu general public license and gnu lesser

general public license respectively, it is distributed in the hope that it will be useful, but without any warranty, without even

the implied warranty of merchantability or fitness for a particular purpose. As for the terms and conditions, please refer to the

software license of the supplied CD-ROM.

If you wish to ask any questions as to the software, please contact (oss-cd-request@gg.jp.panasonic.com) by email.

Notice about AVC/VC-1/MPEG-4

This product is licensed under the AVC Patent Portfolio License, VC-1 Patent Portfolio License and MPEG-4 Visual Patent Portfolio License for the personal use of a consumer or other uses in which it does not receive remuneration to (i) encode video in compliance with the AVC Standard, VC-1 Standard and MPEG-4 Visual Standard ("AVC/VC-1/MPEG-4 Video") and/or (ii) decode AVC/VC-1/MPEG-4 Video that was encoded by a consumer engaged in a personal activity and/or was obtained from a video provider licensed to provide AVC/VC-1/MPEG-4 Video. No license is granted or shall be implied for any other use. Additional information may be obtained from MPEG LA, LLC. See <http://www.mpegla.com>

(for the U.S.A and Puerto Rico)

Panasonic Solutions Company
Unit of Panasonic Corporation of
North America
Two Riverfront Plaza, Newark,
New Jersey 07102-5490

**Panasonic Professional Flat Panel Display
Limited Warranty**

Panasonic Solutions Company. (referred to as “the Warrantor”) will repair this product and all included accessories with new or refurbished parts, free of charge in the USA or Puerto Rico, of the original purchase in the event of a defect in materials or workmanship as follows:

Models or Parts	Part Warranty	Labor Warranty
Professional Flat Panel Display	2 Years	2 Years

On-site or carry-in service in the **USA and Puerto Rico** may be obtained during the warranty period by contacting Panasonic Solutions Company Service toll free at 1-877-655-2357.

This warranty is extended only to the original purchaser and is non transferable. A purchase receipt or other proof of date of original purchase will be required before warranty service is rendered.

This warranty only covers failures due to defects in materials or workmanship, which occur during normal use. The warranty does not cover damage which occur in shipment, or failures which are caused by products not supplied by the warrantor, or failures which result from improper installation, set-up adjustments, improper

antenna, inadequate signal pickup, maladjustment of consumer controls, improper operation, power line surge, improper voltage supply, lighting damage, or service by anyone other than an authorized repair facility, or damage that is attributable to acts of God.

LIMITS AND EXCLUSIONS

There are no express warranties except as listed above.

THE WARRANTOR SHALL NOT BE LIABLE FOR INCIDENTAL OR CONSEQUENTIAL DAMAGES (INCLUDING, WITHOUT LIMITION, DAMAGE TO DISCS) RESULTING FROM THE USE OF THIS PRODUCT, OR ARISING OUT OF ANY BREACH OF THE WARRANTY. ALL EXPRESS AND IMPLIED WARRANTIES, INCLUDING THE WARRANTIES OF MERCHANTABILITY AND FITNESS FOR PARTICULAR PURPOSE, ARE LIMITED TO THE APPLICABLE WARRANTY PERIOD SET FORTH ABOVE.

Some states do not allow the exclusion or limitation of incidental or consequential damages, or limitations on how long an implied warranty lasts, so the above exclusions or limitations may not apply to you. This warranty gives you specific legal rights and you may other rights, which vary from state to state.

If you have a problem with this product that is not handled to your satisfaction, then write the Consumer Affairs Department at the Company address indicated above.

In the USA and Puerto Rico
FOR SERVICE
CALL TOLL FREE
1-877-655-2357

Panasonic Canada Inc.
5770 Ambler Drive, Mississauga, Ontario L4W 2T3
LIMITED WARRANTY STATEMENT

Panasonic Canada Inc. (also known as PCl) warrants this product to be free of defects in material and workmanship under normal use during the applicable warranty period. The warranty period begins on the date of purchase and ends on the date that the product becomes defective. However, the product must be purchased and serviced in Canada. The product or part that shows evidence of defect must be delivered prepaid or carried in to an authorized Panasonic Broadcast Service Center. This warranty does not cover shipping costs.

The warranty coverage period is one year for both parts and labour beginning with the date of original end user purchase, subject to the exceptions as stated below. Repeated or replacement parts supplied during the warranty coverage period carry the unexpired portion of the original warranty coverage period. Proof of product purchase is a condition of warranty service. The owner must produce the product purchase receipt or other satisfactory evidence of date of original purchase.

This warranty does not apply to external appearance items, such as handles, knobs, safety windows, etc. This warranty does not apply to any part or parts of the product that are not covered by the express warranty. The performance of PCl, affects the reliability of or detracts from the performance of the product.

For products requiring routine preventive maintenance, that maintenance must be performed at the discretion of the user.

Serial numbers that have been altered, defaced or removed void this warranty. This warranty does not apply to products that are recalled by PCl, or products that are recalled resulting from any cause beyond the control of PCl.

Merch or retained images (sometimes called "burn-in") resulting from the display of fixed images on video display products are not defects and are not covered under this warranty.

THIS EXPRESS, LIMITED WARRANTY IS IN LIEU OF ALL OTHER WARRANTIES, EXPRESS OR IMPLIED, INCLUDING ANY IMPLIED WARRANTIES OF MERCHANTABILITY AND FITNESS FOR A PARTICULAR PURPOSE. IN NO EVENT WILL PANASONIC CANADA INC. BE LIABLE FOR ANY SPECIAL, INDIRECT OR CONSEQUENTIAL DAMAGES.

In certain instances, some jurisdictions do not allow the exclusion or limitation of incidental or consequential damages, or the exclusion of implied warranties, so the above limitations and exclusions may not be applicable.

WARRANTY COVERAGE PERIOD EXCEPTIONS

Item	Parts	Labour
VHS Tape	30 days—Replacement only (content not covered)	N/A
P2SD Cards	(Content not covered)	N/A
Video Heads	1 year or 2,000 hrs. (prorated)	1 year or 2,000 hrs.
DS Video heads	Whichever comes first	Whichever comes first
Maintenance Items	1 year or 1,000 hrs.	1 year or 1,000 hrs.
Colour Camera CCD Imaging Block	Whichever comes first	Whichever comes first
All LCD Monitors	90 days	90 days
* DLP™ Projectors	2 years (burn-in not covered)	2 years
* LCD Projectors above 2,500 ANSI lumens	3 years or 17,000 hrs.	3 years or 17,000 hrs.
* LCD Projectors below 2,500 ANSI lumens	Whichever comes first	Whichever comes first
Projector Lamps	3 years or 1,500 hrs.	3 years or 1,500 hrs.
All Plasma displays	Whichever comes first	Whichever comes first
103 inch Plasma displays	50% of the rated lamp life or 1 year.	50% of the rated lamp life or 1 year.
Hard Drive Disk Unit	2 years (burn-in not covered)	2 years
Limited Warranty.	1 year plus balance (if any) of the original Manufacturer's Limited Warranty.	1 year

* Dust, smoke, rental/staging environment and twenty-four/seven operation dramatically decreases the interval between performances of routine preventive maintenance required to maintain this warranty coverage.

Warranty Service

If the product needs to be shipped for service, carefully pack (preferably in the original carton) and enclose a letter, detailing the complaint. Send prepaid and adequately insured to the local authorized Panasonic Service Center in your area. For a list of authorized Panasonic Service Centers, call 1-800-4-A-PANASONIC, Ambler Drive, Mississauga, Ontario, L4W 2T3. Shipping to the letter location requires a return authorization before shipment. No liability is assumed for loss or damage to the product while in transit.

Customer Service

Customer Service Directory

Obtain products information and operative assistant; localize the closer distributor or Service Center; buy spare parts and accessories by our web site to Latin American:

<http://www.lar.panasonic.com>

Also you may contact us directly by our Contact Center:

Panama	800-PANA (800-7262)
Colombia	01-8000-94PANA (01-8000-947262)
Ecuador	1800-PANASONIC (1800-726276)
Costa Rica	800-PANA737 (800-7262737)
El Salvador	800-PANA (800-7262)
Guatemala	1-801-811-PANA (1-801-811-7262)
Chile	800-390-602
	From a cell phone: 797-5000
Venezuela	800-PANA-800 (800-7262-800)
Uruguay	0-800-PANA (0-800-7262)
Peru	0-800-00-PANA (0-800-00726)
Argentina	0800-333-PANA (0800-333-7262)
	0810-321-PANA (0810-321-7262)
Paraguay	800-11-PANA (800-11-7262)
Dominican Republic	809-200-8000

Mexico Service

To obtain information in the Republic of Mexico contact us at:

[email: atencion.clientes@mx.panasonic.com](mailto:atencion.clientes@mx.panasonic.com)

<http://www.panasonic.com.mx>

Or you may contact us in the next following phones numbers:

01800-VIP-PANA (01800-847-7262) - Interior
(55) 5000-1200 - Mexico D.F. and Metropolitan Area

Disposal of Old Equipment and Batteries

Only for European Union and countries with recycling systems



These symbols on the products, packaging, and/or accompanying documents mean that used electrical and electronic products and batteries must not be mixed with general household waste. For proper treatment, recovery and recycling of old products and used batteries, please take them to applicable collection points in accordance with your national legislation.

By disposing of them correctly, you will help to save valuable resources and prevent any potential negative effects on human health and the environment.

For more information about collection and recycling, please contact your local municipality.

Penalties may be applicable for incorrect disposal of this waste, in accordance with national legislation.

EU



Note for the battery symbol (bottom symbol)

This symbol might be used in combination with a chemical symbol. In this case it complies with the requirement set by the Directive for the chemical involved.

Information on Disposal in other Countries outside the European Union

These symbols are only valid in the European Union.

If you wish to discard these items, please contact your local authorities or dealer and ask for the correct method of disposal.

USA only: Disposal may be regulated in your community due to environmental considerations. For disposal or recycling information, please visit Panasonic website: <http://www.panasonic.com/environmental> or call 1-888-769-0149.

Customer's Record

The model number and serial number of this product may be found on its rear panel. You should note this serial number in the space provided below and retain this book, plus your purchase receipt, as a permanent record of your purchase to aid in identification in the event of theft or loss, and for Warranty Service purposes.

Model Number _____

Serial Number _____

For TH-80BF1U, TH-65BF1U and TH-50BF1U

Panasonic System Communications Company of North America

Unit of Panasonic Corporation of North America

Executive Office :

Two Riverfront Plaza, Newark, New Jersey 07102-5490

Panasonic Canada Inc.

5770 Ambler Drive

Mississauga, Ontario

L4W 2T3

For TH-80BF1E, TH-65BF1E and TH-50BF1E

Panasonic Testing Centre

Panasonic Service Europe, a division of Panasonic Marketing Europe GmbH

Winsbergring 15, 22525 Hamburg, F.R. Germany

Panasonic Corporation

Web Site : <https://panasonic.net/cns/prodisplays/>

© Panasonic Corporation 2016

TI0416TS3127 -PB

Printed in China