

# Panasonic®

Model No.

**TH-70LF50U**

**TH-80LF50U**

## Operating Instructions

FULL HD LCD Display

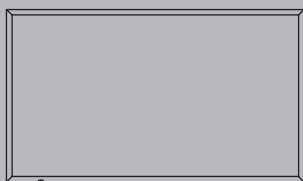

**English**

Before connecting, operating or adjusting this product,  
please read these instructions completely.  
Please keep this manual for future reference.

**HDMI**

	<b>CAUTION</b> <b>RISK OF ELECTRIC SHOCK</b> <b>DO NOT OPEN</b>	
<b>WARNING: To reduce the risk of electric shock, do not remove cover or back. No user-serviceable parts inside. Refer servicing to qualified service personnel.</b>		



The lightning flash with arrow-head within a triangle is intended to tell the user that parts inside the product are a risk of electric shock to persons.



The exclamation point within a triangle is intended to tell the user that important operating and servicing instructions are in the papers with the appliance.

**WARNING :** To prevent damage which may result in fire or shock hazard, do not expose this apparatus to rain or moisture.  
Do not place containers with water (flower vase, cups, cosmetics, etc.) above the set. (including on shelves above, etc.)

**WARNING :** 1) To prevent electric shock, do not remove cover. No user serviceable parts inside. Refer servicing to qualified service personnel.  
2) Do not remove the grounding pin on the power plug. This apparatus is equipped with a three pin grounding-type power plug. This plug will only fit a grounding-type power outlet. This is a safety feature. If you are unable to insert the plug into the outlet, contact an electrician.  
Do not defeat the purpose of the grounding plug.

# Important Safety Instructions

- 1) Read these instructions.
- 2) Keep these instructions.
- 3) Heed all warnings.
- 4) Follow all instructions.
- 5) Do not use this apparatus near water.
- 6) Clean only with dry cloth.
- 7) Do not block any ventilation openings. Install in accordance with the manufacturer's instructions.
- 8) Do not install near any heat sources such as radiators, heat registers, stoves, or other apparatus (including amplifiers) that produce heat.
- 9) Do not defeat the safety purpose of the polarized or grounding-type plug. A polarized plug has two blades with one wider than the other. A grounding type plug has two blades and a third grounding prong. The wide blade or the third prong are provided for your safety. If the provided plug does not fit into your outlet, consult an electrician for replacement of the obsolete outlet.
- 10) Protect the power cord from being walked on or pinched particularly at plugs, convenience receptacles, and the point where they exit from the apparatus.
- 11) Only use attachments / accessories specified by the manufacturer.
- 12) Use only with the cart, stand, tripod, bracket, or table specified by the manufacturer, or sold with the apparatus. When a cart is used, use caution when moving the cart / apparatus combination to avoid injury from tip-over.
- 13) Unplug this apparatus during lightning storms or when unused for long periods of time.
- 14) Refer all servicing to qualified service personnel. Servicing is required when the apparatus has been damaged in any way, such as power-supply cord or plug is damaged, liquid has been spilled or objects have fallen into the apparatus, the apparatus has been exposed to rain or moisture, does not operate normally, or has been dropped.
- 15) To prevent electric shock, ensure the grounding pin on the AC cord power plug is securely connected.



# Dear Panasonic Customer

Welcome to the Panasonic family of customers. We hope that you will have many years of enjoyment from your new LCD Display.

To obtain maximum benefit from your set, please read these Instructions before making any adjustments, and retain them for future reference.

Retain your purchase receipt as well, and record the model number and serial number of your set in the space provided on the rear cover of these instructions.

Visit our Panasonic Web Site <http://panasonic.net>

## Table of Contents

<b>Important Safety Instructions</b> .....	<b>3</b>	<b>Customizing the Input labels</b> .....	<b>36</b>
<b>FCC STATEMENT</b> .....	<b>5</b>	<b>Selecting the On-Screen Menu Language</b> .....	<b>37</b>
<b>Safety Precautions</b> .....	<b>6</b>	<b>Customizing the On-Screen Menu Display</b> .....	<b>37</b>
<b>Maintenance</b> .....	<b>7</b>	<b>SET UP for MULTI DISPLAY</b> .....	<b>38</b>
<b>Accessories</b> .....	<b>8</b>	How to setup MULTI DISPLAY .....	38
Accessories Supplied .....	8	ID Remote Control Function .....	39
Remote Control Batteries .....	8	<b>SET UP for Input Signals</b> .....	<b>40</b>
<b>Ceiling Suspension</b> .....	<b>9</b>	COMPONENT / RGB IN SELECT .....	40
<b>Connections</b> .....	<b>10</b>	YUV / RGB IN SELECT .....	40
AC cord connection and fixing.....	10	SIGNAL menu .....	41
Video equipment connection .....	11	3D Y/C FILTER.....	41
AUDIO OUT connection .....	11	COLOR SYSTEM.....	42
VIDEO, COMPONENT / RGB IN and HDMI connection ...	12	3:2 PULLDOWN .....	42
DVI-D IN, DVI-D OUT connection .....	13	XGA MODE .....	42
PC Input Terminals connection.....	14	NOISE REDUCTION.....	43
SERIAL Terminals connection .....	15	SYNC .....	43
<b>Power ON / OFF</b> .....	<b>17</b>	HDMI RANGE .....	43
<b>Selecting the input signal</b> .....	<b>19</b>	Input signal display.....	44
<b>Basic Controls</b> .....	<b>20</b>	<b>Network Setup</b> .....	<b>45</b>
<b>ASPECT Controls</b> .....	<b>22</b>	<b>Options Adjustments</b> .....	<b>46</b>
<b>Digital Zoom</b> .....	<b>23</b>	Input Search .....	48
<b>On-Screen Menu Displays</b> .....	<b>24</b>	<b>Using Network Function</b> .....	<b>49</b>
<b>Adjusting POS. /SIZE</b> .....	<b>25</b>	Example of Network Connection .....	49
<b>PICTURE Adjustments</b> .....	<b>27</b>	Command Control .....	49
ADVANCED SETTINGS.....	28	PLink™ Protocol.....	50
<b>SOUND Adjustment</b> .....	<b>29</b>	<b>Using Web Browser Control</b> .....	<b>51</b>
SDI SOUND OUTPUT.....	29	Before Using Web Browser Control.....	51
<b>PRESENT TIME SETUP / SET UP TIMER</b> .....	<b>30</b>	Access from Web Browser .....	51
PRESENT TIME SETUP .....	30	Display Control (BASIC CONTROL/OPTION CONTROL Screen) ...	52
SET UP TIMER .....	31	NETWORK SETTING (Network Setup Screen) ....	53
<b>SCREENSAVER (For preventing image retention) ...</b>	<b>32</b>	Password Setting (Password Setup Screen) .....	53
Setup of SCREENSAVER Time .....	33	<b>Troubleshooting</b> .....	<b>54</b>
<b>WOBBLING</b> .....	<b>33</b>	<b>Applicable input signals</b> .....	<b>55</b>
<b>NO ACTIVITY POWER OFF</b> .....	<b>34</b>	<b>Shipping condition</b> .....	<b>57</b>
<b>ECO MODE SETTINGS</b> .....	<b>35</b>	<b>Specifications</b> .....	<b>58</b>

# FCC STATEMENT

This equipment has been tested and found to comply with the limits for a Class B digital device, pursuant to Part 15 of the FCC Rules. These limits are designed to provide reasonable protection against harmful interference in a residential installation. This equipment generates, uses and can radiate radio frequency energy and, if not installed and used in accordance with the instructions, may cause harmful interference to radio communications. However, there is no guarantee that interference will not occur in a particular installation. If this equipment does cause harmful interference to radio or television reception, which can be determined by turning the equipment off and on, the user is encouraged to try to correct the interference by one or more of the following measures:

- Reorient or relocate the receiving antenna.
- Increase the separation between the equipment and receiver.
- Connect the equipment into an outlet on a circuit different from that to which the receiver is connected.
- Consult the dealer or an experienced technician for help.

This device complies with Part 15 of the FCC Rules. Operation is subject to the following two conditions: (1) This device may not cause harmful interference, and (2) this device must accept any interference received, including interference that may cause undesired operation.

## **FCC CAUTION:**

**To assure continued compliance, follow the attached installation instructions and use only shielded interface cables when connecting to computer or peripheral devices. Any changes or modifications not expressly approved by Panasonic Corp. of North America could void the user's authority to operate this device.**

### FCC Declaration of Conformity

Model No. TH-70LF50U, TH-80LF50U

Responsible Party:	Panasonic Corporation of North America Three Panasonic Way 2F-5, Secaucus, NJ 07094
Contact Source:	Panasonic System Communications Company of North America 1-885-772-8324

## **CANADIAN NOTICE:**

This Class B digital apparatus complies with Canadian ICES-003.

## **Note:**

Image retention may occur. If you display a still picture for an extended period, the image might remain on the screen. However, it will disappear after a while.

## **Trademark Credits**

- VGA is a trademark of International Business Machines Corporation.
- Macintosh is a registered trademark of Apple Inc., USA.
- SVGA, XGA, SXGA and UXGA are registered trademarks of the Video Electronics Standard Association.  
Even if no special notation has been made of company or product trademarks, these trademarks have been fully respected.
- HDMI, the HDMI Logo, and High-Definition Multimedia Interface are trademarks or registered trademarks of HDMI Licensing LLC in the United States and other countries.

# Safety Precautions

## CAUTION

**This LCD Display is for use only with the following optional accessories. Use with any other type of optional accessories may cause instability which could result in the possibility of injury.**

(All of the following accessories are manufactured by Panasonic Corporation.)

- Pedestal ..... TY-ST58P20 (for TH-70LF50U)  
TY-ST65P20 (for TH-80LF50U)
- Wall-hanging bracket (vertical) ..... TY-WK70PV50
- HD-SDI Terminal Board with audio ..... TY-FB10HD
- Protective Glass ..... TY-PG70LF50 (for TH-70LF50U)  
TY-PG80LF50 (for TH-80LF50U)

Always be sure to ask a qualified technician to carry out set-up.

Small parts can present choking hazard if accidentally swallowed. Keep small parts away from young children. Discard unneeded small parts and other objects, including packaging materials and plastic bags/sheets to prevent them from being played with by young children, creating the potential risk of suffocation.

### ■ When using the LCD Display

**Do not bring your hands, face or objects close to the ventilation holes of the Display.**

- Top of the Display is usually very hot due to the high temperature of exhaust air being released through the ventilation holes. Burns or personal injuries can happen if any body parts are brought too close. Placing any object near the top of the display could also result in heat damages to the object as well as to the Display if its ventilation holes are blocked.

**Be sure to disconnect all cables before moving the Display.**

- Moving the Display with its cables attached might damage the cables which, in turn, can cause fire or electric shock.

**Disconnect the power plug from the wall outlet as a safety precaution before carrying out any cleaning.**

- Electric shocks can result if this is not done.

**Clean the power cable regularly to prevent it from becoming dusty.**

- Built-up dust on the power cord plug can increase humidity which might damage the insulation and cause fire. Unplug the cord from the wall outlet and clean it with a dry cloth.

#### **Note:**

Image retention may occur. If you display a still picture for an extended period, the image might remain on the screen. However, it will disappear after a while.

### WARNING

#### ■ Setup

**Do not place the Display on sloped or unstable surfaces, and ensure that the Display does not hang over the edge of the base.**

- The Display may fall off or tip over.

**Do not place any objects on top of the Display.**

- If water spills onto the Display or foreign objects get inside it, a short-circuit may occur which could result in fire or electric shock. If any foreign objects get inside the Display, please consult an Authorized Service Center.

**Do not cover the ventilation holes.**

- Doing so may cause the Display to overheat, which can cause fire or damage to the Display.

**Transport only in upright position!**

- Transporting the unit with its display panel facing upright or downward may cause damage to the internal circuitry.

**For sufficient ventilation;**

**Leave a space of 3 15/16" (10 cm) or more at the top, left and right, and 2 3/4" (7 cm) or more at the rear, and also keep the space between the bottom of the display and the floor surface.**

**Cautions for Wall Installation**

- Wall installation should be performed by an installation professional. Installing the Display incorrectly may lead to an accident that results in death or serious injury. Use the specified optional accessories.
- When installing the Display vertically, be sure to install the power indicator onto the top of the Display.

**Caution for Ceiling Suspension**

- Ceiling suspension should be performed by an installation professional. Installing the Display incorrectly may lead to an accident that results in death or serious injury.

**An apparatus with CLASS I construction shall be connected to a mains socket outlet with a protective earthing connection.**

**Do not install the product to a place where the product is exposed to direct sunlight.**

- If the screen is exposed to direct sunlight, the liquid crystal panel may have adverse effect.

#### ■ AC Power Supply Cord

The Display is designed to operate on 110 - 127 V AC, 50/60 Hz.

**Ensure that the mains plug is easily accessible.**

**Do not use any power supply cord other than that provided with this unit.**

- Doing so may cause fire or electric shocks.

**Securely insert the power cord plug as far as it will go.**

- If the plug is not fully inserted, heat may be generated which could cause fire. If the plug is damaged or the wall socket plate is loose, they should not be used.

**Do not handle the power cord plug with wet hands.**

- Doing so may cause electric shocks.

**Do not do anything that might damage the power cable. When disconnecting the power cable, hold the plug, not the cable.**

- Do not make any modifications, place heavy objects on, place near hot objects, heat, bend, twist or forcefully pull the power cable. Doing so may cause damage to the power cable which can cause fire or electric shock. If damage to the cable is suspected, have it repaired at an Authorized Service Center.

**If the Display will not be used for a long period of time, unplug the power cord from the wall outlet.**

#### ■ If problems occur during use

**If a problem occurs (such as no picture or no sound), or if smoke or an abnormal odor is detected from the Display, unplug the power cord immediately.**

- Continuous use of the Display under these conditions might cause fire or permanent damage to the unit. Have the Display evaluated at an Authorized Service Center. Services to the Display by any unauthorized personnel are strongly discouraged due to its high voltage dangerous nature.

**If water or foreign objects get inside the Display, if the Display is dropped, or if the cabinet becomes damaged, disconnect the power cord plug immediately.**

- A short may occur, which could cause fire. Contact an Authorized Service Center for any repairs that need to be made.

## Maintenance

**The front of the display panel has been specially treated. Wipe the panel surface gently using only a cleaning cloth or a soft, lint-free cloth.**

- If the surface is particularly dirty, wipe with a soft, lint-free cloth which has been soaked in pure water or water in which neutral detergent has been diluted 100 times, and then wipe it evenly with a dry cloth of the same type until the surface is dry.
- Do not scratch or hit the surface of the panel with fingernails or other hard objects, otherwise the surface may become damaged. Furthermore, avoid contact with volatile substances such as insect sprays, solvents and thinner, otherwise the quality of the surface may be adversely affected.

**If the cabinet becomes dirty, wipe it with a soft, dry cloth.**

- If the cabinet is particularly dirty, soak the cloth in water to which a small amount of neutral detergent has been added and then wring the cloth dry. Use this cloth to wipe the cabinet, and then wipe it dry with a dry cloth.
- Do not allow any detergent to come into direct contact with the surface of the Display. If water droplets get inside the unit, operating problems may result.
- Avoid contact with volatile substances such as insect sprays, solvents and thinner, otherwise the quality of the cabinet surface may be adversely affected or the coating may peel off. Furthermore, do not leave it for long periods in contact with articles made from rubber or PVC.

**Usage of a chemical cloth**

- Do not use a chemical cloth for the panel surface.
- Follow the instructions for the chemical cloth to use it for the cabinet.

# Accessories

## Accessories Supplied

Check that you have the Accessories and items shown

Operating Instruction book

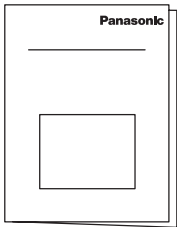

CD-ROM (Operating instructions)

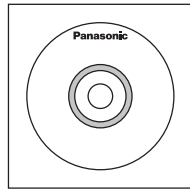

Remote Control Transmitter N2QAYB000691



Batteries for the Remote Control Transmitter (AA Size × 2)

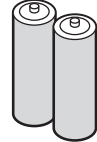

AC cord

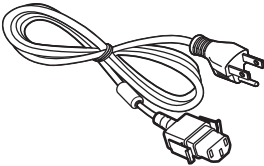

Clamper × 1 TMME289

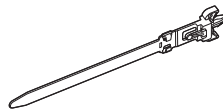

## Remote Control Batteries

Requires two AA batteries.

1. Pull and hold the hook, then open the battery cover.

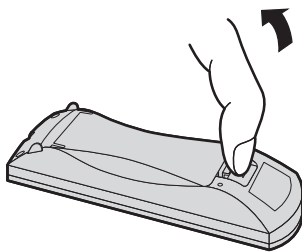

2. Insert batteries - note correct polarity (+ and -).

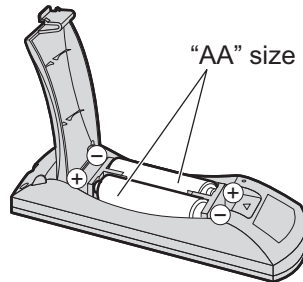

3. Replace the cover.

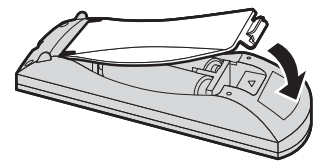

### Helpful Hint:

For frequent remote control users, replace old batteries with Alkaline batteries for longer life.

### ⚠ Precaution on battery use

Incorrect installation can cause battery leakage and corrosion that will damage the remote control transmitter. Disposal of batteries should be in an environment-friendly manner.

**Observe the following precautions:**

1. Batteries should always be replaced as a pair. Always use new batteries when replacing the old set.
2. Do not combine a used battery with a new one.
3. Do not mix battery types (example: "Zinc Carbon" with "Alkaline").
4. Do not attempt to charge, short-circuit, disassemble, heat or burn used batteries.
5. Battery replacement is necessary when the remote control acts sporadically or stops operating the Display.
6. Do not burn or breakup batteries.

Batteries must not be exposed to excessive heat such as sunshine, fire or the like.



# Ceiling Suspension

You can install the Display by attaching commercially available eyebolts (M10) to it and suspending it from the ceiling, etc.

Eyebolt mounting positions  
(for horizontal installation)

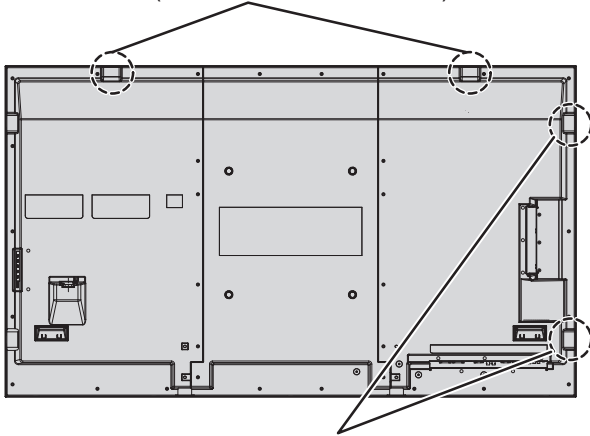

Eyebolt mounting positions  
(for vertical installation)

## Notes:

- Suspension and installation should be performed by an installation professional.
- Do not install it using only one eyebolt.
- When the Display is installed horizontally, make sure to place the power Indicator side down and, face up the power Indicator side, when it is installed vertically.
- Install the wire along the vertical side when suspending the Display.

# Connections

## AC cord connection and fixing, cable fixing

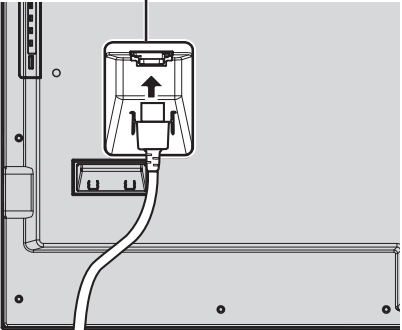

AC cord  
(accessory)

**AC cord fixing**

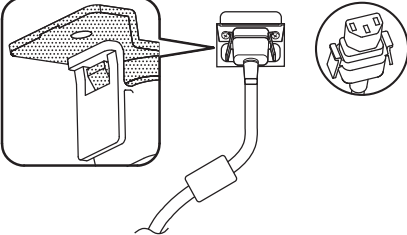
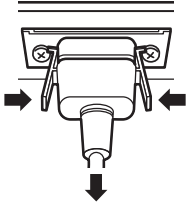
**Plug the AC cord into the display unit.**  
Plug the AC cord until it clicks.

**Note:**  
Make sure that the AC cord is locked on both the left and right sides.

**Unplug the AC cord**

Unplug the AC cord pressing the two knobs.

**Note:**  
When disconnecting the AC cord, be absolutely sure to disconnect the AC cord plug at the socket outlet first.

### Using the clamper

Secure any excess cables with clamper as required.

**Note:**

One clamper is supplied with this unit. In case of securing cables at four positions, please purchase it separately.

TH-70LF50U

TH-80LF50U

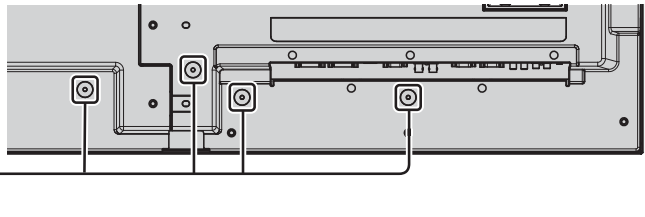
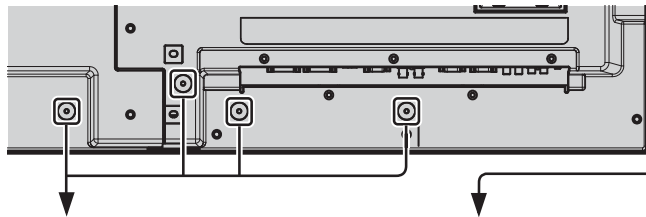

**1 Attach the clamper**

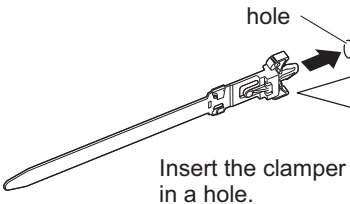

hole

Insert the clamper in a hole.

**To remove from the unit:**

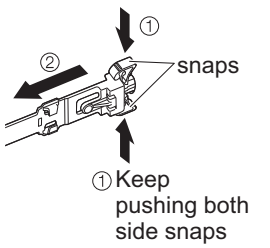

snaps

① Keep pushing both side snaps

**2 Bundle the cables**

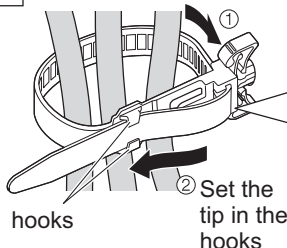

hooks

② Set the tip in the hooks

**To loosen:**

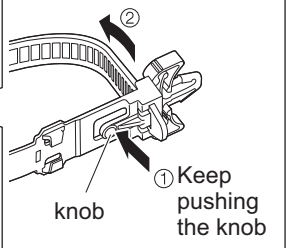

knob

① Keep pushing the knob

## Video equipment connection

Ex. TH-80LF50U

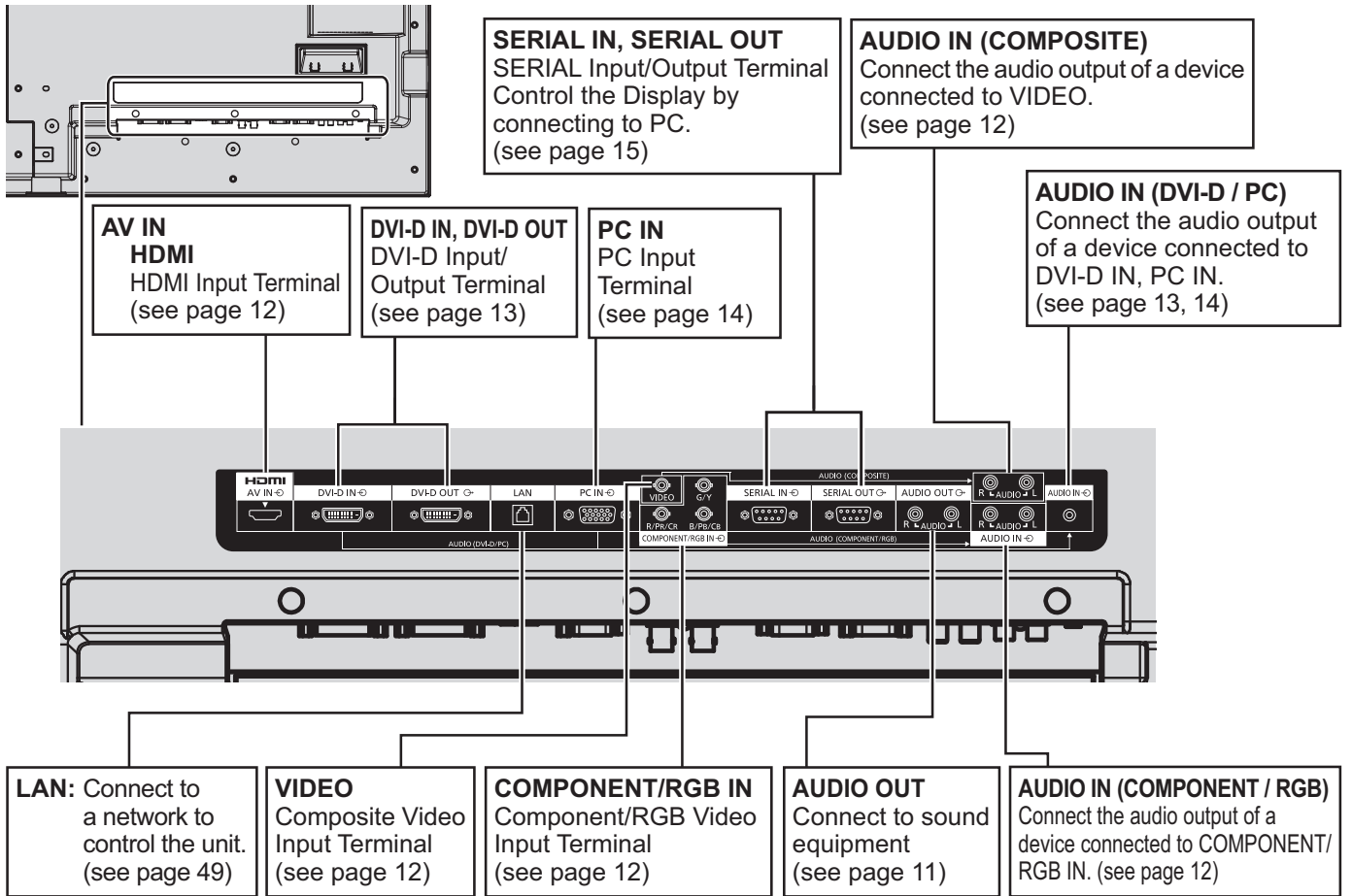

## AUDIO OUT connection

**Note:**

Additional equipment and cables shown are not supplied with this set.

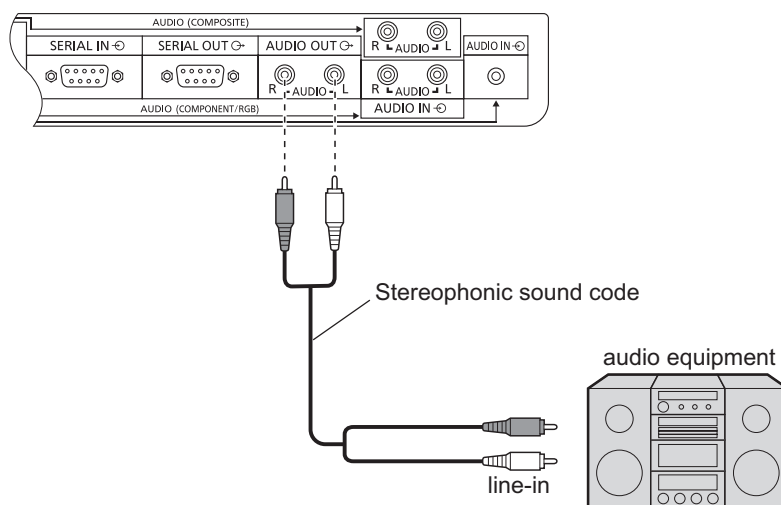

# Connections

## VIDEO, COMPONENT / RGB IN and HDMI connection

**Note:**

Additional equipment, cables and adapter plugs shown are not supplied with this set.

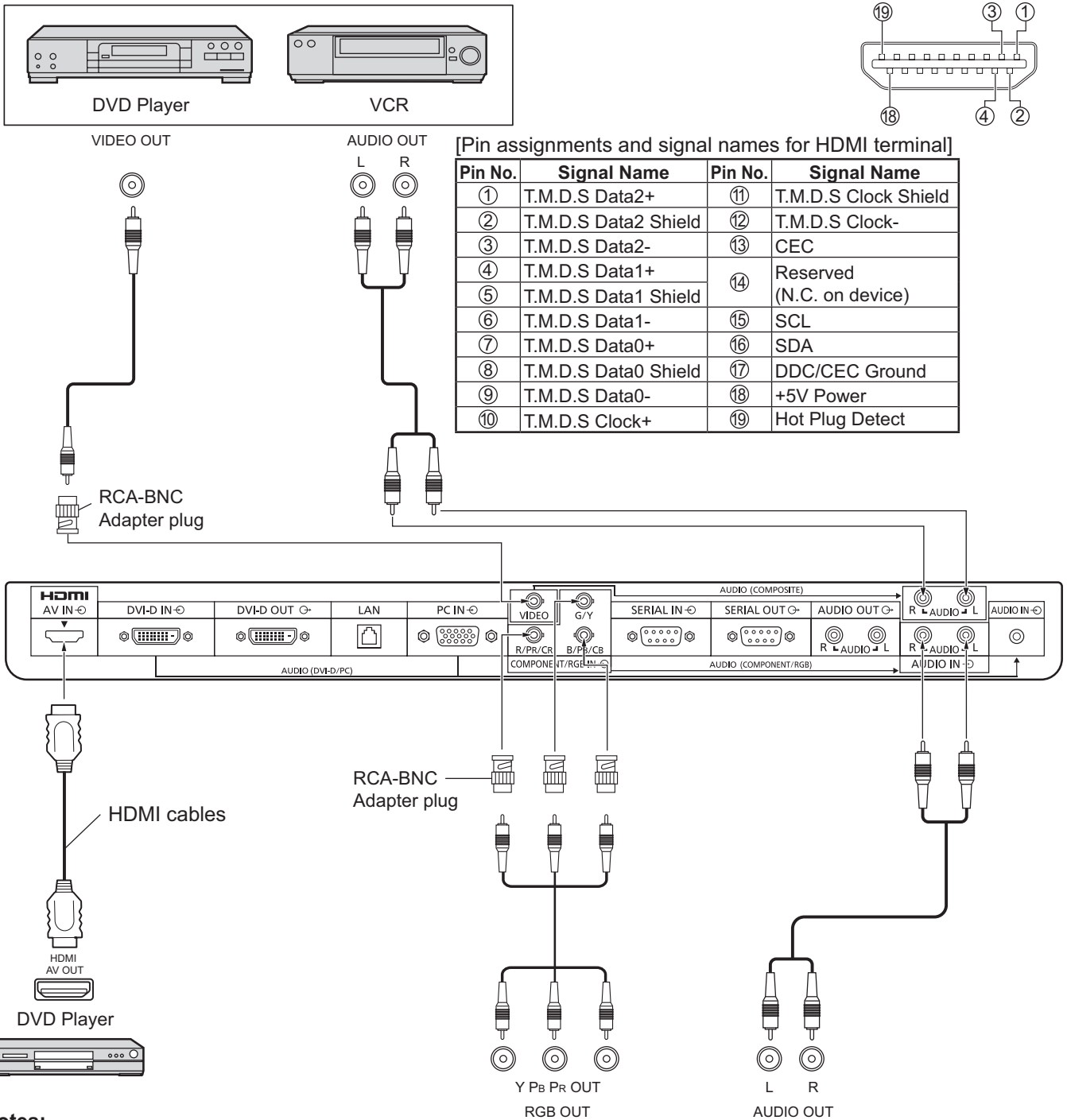

**Notes:**

- Change the "COMPONENT/RGB-IN SELECT" setting in the "SETUP" menu to "COMPONENT" (when COMPONENT signal connection) or "RGB" (when RGB signal connection). (see page 40)
- Accepts only RGB signals from COMPONENT/RGB IN terminal with "SYNC ON G".

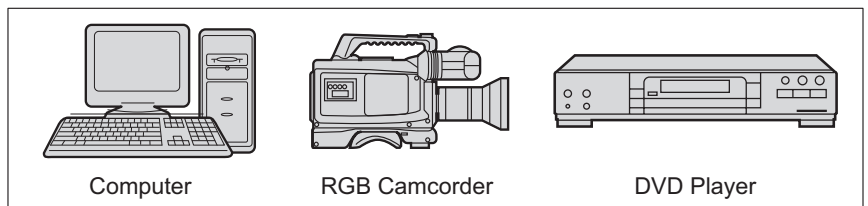

# DVI-D IN, DVI-D OUT connection

PC with DVI-D video out

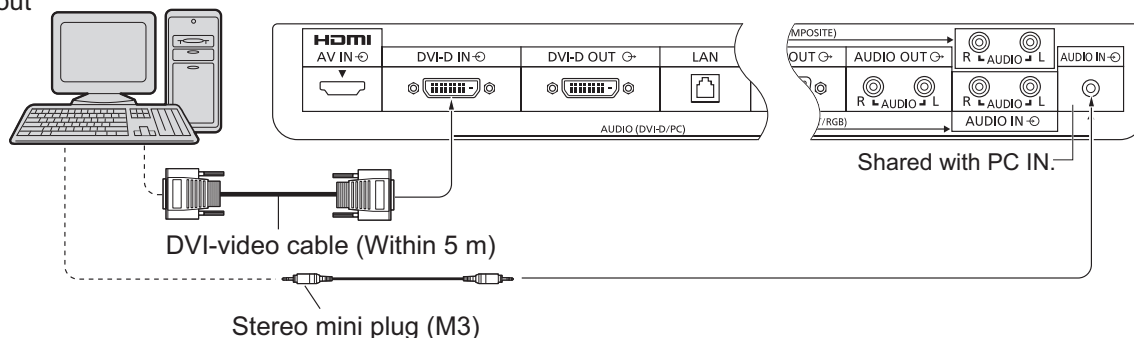

## Daisy chain connection

When using the multi display, multiple LCD Displays can be daisy chained.

PC with DVI-D video out

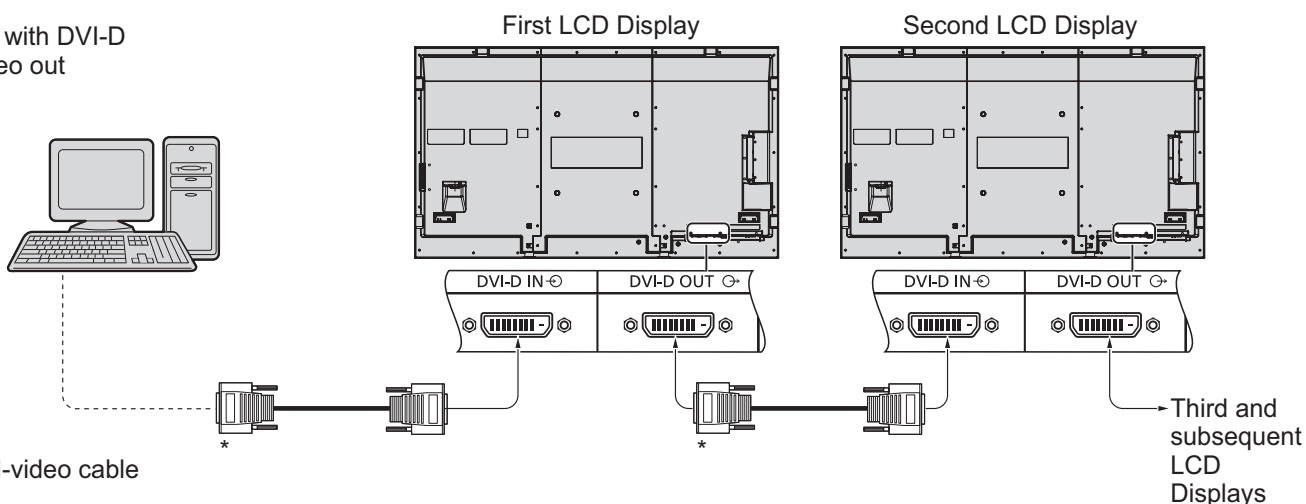

\* DVI-video cable

### Notes:

- Up to 10 displays can be connected with a daisy chain, but the number of the connected displays may be limited by a cable, signal or equipment to use.
- HDCP signals can be processed, with up to 8 displays connected via a daisy chain connection.

### DVI-D Input/Output Connector Pin Layouts

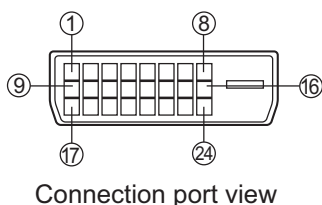

Pin No.	Signal Name	Pin No.	Signal Name
①	T.M.D.S. data 2-	⑬	
②	T.M.D.S. data 2+	⑭	+5 V DC
③	T.M.D.S. data 2 shield	⑮	Ground
④		⑯	Hot plug detect
⑤		⑰	T.M.D.S. data 0-
⑥	DDC clock	⑱	T.M.D.S. data 0+
⑦	DDC data	⑲	T.M.D.S. data 0 shield
⑧		⑳	
⑨	T.M.D.S. data 1-	㉑	
⑩	T.M.D.S. data 1+	㉒	T.M.D.S. clock shield
⑪	T.M.D.S. data 1 shield	㉓	T.M.D.S. clock+
⑫		㉔	T.M.D.S. clock-

### Note:

- Additional equipment and cables shown are not supplied with this set.

## PC Input Terminals connection

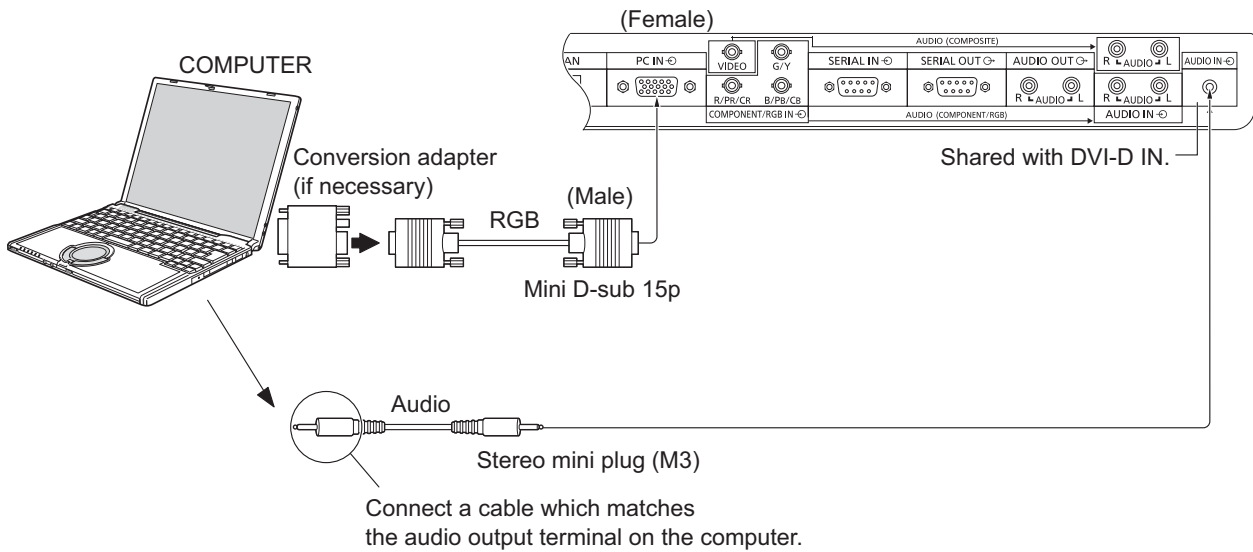

### Notes:

- Computer signals which can be input are those with a horizontal scanning frequency of 30 to 110 kHz and vertical scanning frequency of 48 to 120 Hz. (However, the image will not be displayed properly if the signals exceed 1,200 lines.)
- The display resolution is a maximum of 1,440 × 1,080 dots when the aspect mode is set to "4:3", and 1,920 × 1,080 dots when the aspect mode is set to "FULL". If the display resolution exceeds these maximums, it may not be possible to show fine detail with sufficient clarity.
- The PC input terminals are DDC2B-compatible. If the computer being connected is not DDC2B-compatible, you will need to make setting changes to the computer at the time of connection.
- Some PC models cannot be connected to the set.
- There is no need to use an adapter for computers with DOS/V compatible Mini D-sub 15P terminal.
- The computer shown in the illustration is for example purposes only.
- Additional equipment and cables shown are not supplied with this set.
- Do not set the horizontal and vertical scanning frequencies for PC signals which are above or below the specified frequency range.

### Signal Names for Mini D-sub 15P Connector

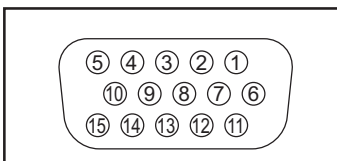

Pin Layout for PC Input Terminal

Pin No.	Signal Name	Pin No.	Signal Name	Pin No.	Signal Name
①	R	⑥	GND (Ground)	⑪	NC (not connected)
②	G	⑦	GND (Ground)	⑫	SDA
③	B	⑧	GND (Ground)	⑬	HD/SYNC
④	NC (not connected)	⑨	+5 V DC	⑭	VD
⑤	GND (Ground)	⑩	GND (Ground)	⑮	SCL

# SERIAL Terminals connection

The SERIAL terminal is used when the Display is controlled by a computer.

**Note:** To use serial control for this unit, make sure to set the “CONTROL I/F SELECT” in the “NETWORK SETUP” menu to “RS-232C”. (see page 45)

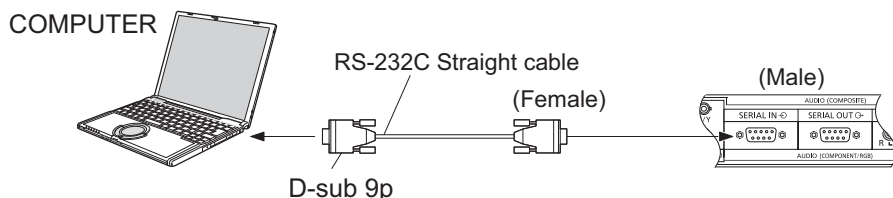

In addition, a particular LCD Display can be controlled with a PC while several LCD Displays are daisy chained.

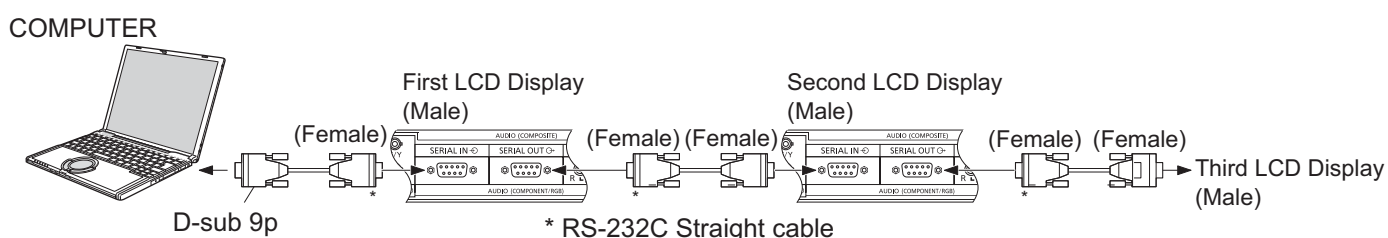

**Notes:**

- Use the RS-232C straight cable to connect the computer to the Display.
- The computer shown is for example purposes only.
- Additional equipment and cables shown are not supplied with this set.
- When using daisy chain, set “Serial Daisy Chain” in the Options menu. (see page 47)
- For daisy chain connection, use a straight cable connected to pins numbered ② through ⑧.

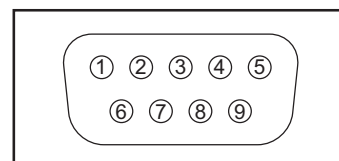

Pin layout for SERIAL Terminal

The SERIAL terminal conforms to the RS-232C interface specification, so that the Display can be controlled by a computer which is connected to this terminal.

The computer will require software which allows the sending and receiving of control data which satisfies the conditions given below. Use a computer application such as programming language software. Refer to the documentation for the computer application for details.

**Communication parameters**

Signal level	RS-232C compliant
Synchronization method	Asynchronous
Baud rate	9600 bps
Parity	None
Character length	8 bits
Stop bit	1 bit
Flow control	-

**Signal names for SERIAL IN terminal**

Pin No.	Details
②	R X D
③	T X D
④	DTR
⑤	GND
⑥	DSR
⑦ ⑧	← (Shorted in this set)
① • ⑨	NC

These signal names are those of computer specifications.

# Connections

## Basic format for control data

The transmission of control data from the computer starts with a STX signal, followed by the command, the parameters, and lastly an ETX signal in that order. If there are no parameters, then the parameter signal does not need to be sent.

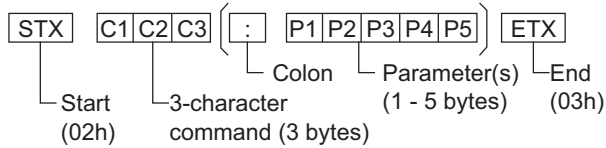

### Notes:

- If multiple commands are transmitted, be sure to wait for the response for the first command to come from this unit before sending the next command.
- If an incorrect command is sent by mistake, this unit will send an “ER401” command back to the computer.
- Consult an Authorized Service Center for detail instructions on command usage.
- S1A and S1B of Command IMS are available only when a dual input terminal board is attached.

## Command

Command	Parameter	Control details
PON	None	Power ON
POF	None	Power OFF
AVL	***	Volume 000 - 100
AMT	0	Audio MUTE OFF
	1	Audio MUTE ON
IMS	None	Input select (toggle)
	SL1	SLOT input (SLOT INPUT)
	S1A	SLOT input (SLOT INPUT A)
	S1B	SLOT input (SLOT INPUT B)
	AV1	VIDEO input (VIDEO)
	AV2	COMPONENT/RGB IN input (Component)
	HM1	HDMI input (HDMI)
DV1	DVI-D IN input (DVI)	
PC1	PC IN input (PC)	
DAM	None	Screen mode select (toggle)
	ZOOM	ZOOM1
	FULL	FULL
	NORM	4:3
	ZOM2	ZOOM2

With the power off, this display responds to PON command only.



# Power ON / OFF

Connecting the AC cord plug to the Display.

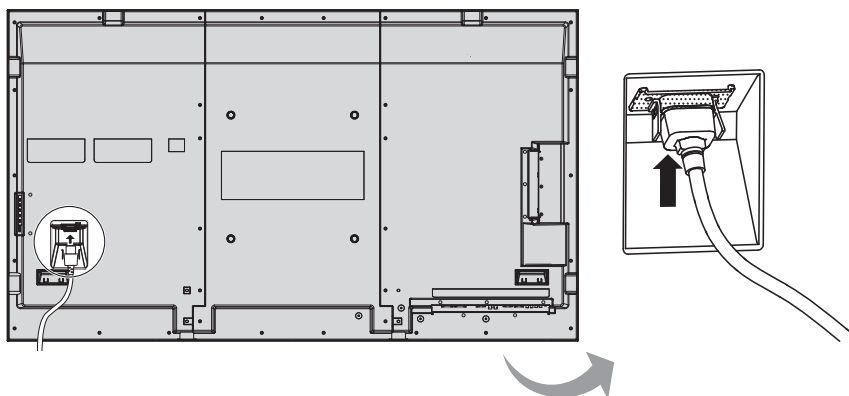

Connecting the plug to the Wall Outlet.

**Note:**

When disconnecting the AC cord, be absolutely sure to disconnect the AC cord plug at the socket outlet first.

Press the Power switch on the Display to turn the set on: Power-On.

Power Indicator: Green

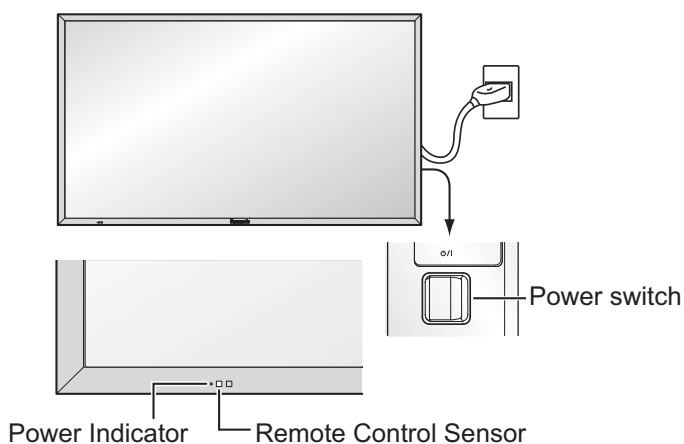

**POWER**



Press the  button on the remote control to turn the Display off.

Power Indicator: Red (standby)

Press the  button on the remote control to turn the Display on.

Power Indicator: Green

Turn the power to the Display off by pressing the  switch on the unit, when the Display is on or in standby mode.

**Note:**

During operation of the power management function, the power indicator turns orange in the power off state.

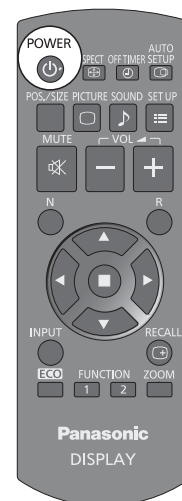

# Power ON / OFF

## When first switching on the unit

Following screen will be displayed when the unit is turned on for the first time. Select the items with the remote control. Unit buttons are invalid.

### OSD LANGUAGE

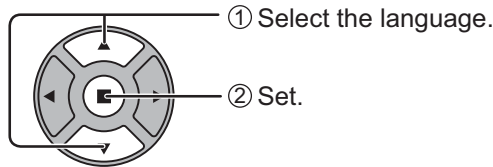

### PRESENT TIME SETUP

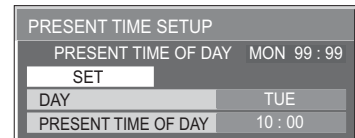
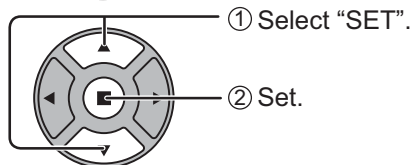
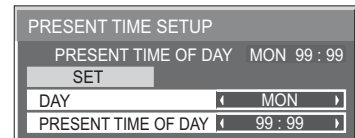
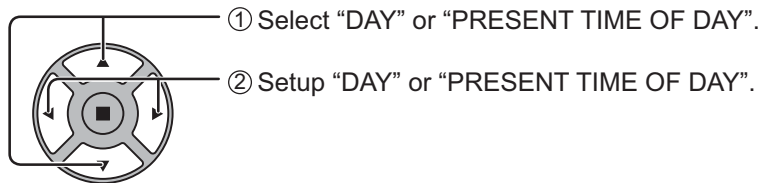

### Notes:

- Once the items are set, the screens won't be displayed when switching on the unit next time.
- After the setting, the items can be changed in the following menus.
  - OSD LANGUAGE (see page 37)
  - PRESENT TIME SETUP (see page 30)

### Power ON warning message

The following message may be displayed when turning the unit power ON:

### No activity power off Precautions

'NO ACTIVITY POWER OFF' IS ENABLED.

If "NO ACTIVITY POWER OFF" in SET UP menu is set to "ENABLE", a warning message is displayed every time the power is turned ON. (see page 34)

This message display can be set with the following menu: Options menu

Power On Message (see page 48)

# Selecting the input signal

INPUT



Press to select the input signal to be played back from the equipment which has been connected to the Display.

Input signals will change as follows:

→ HDMI → VIDEO → Component\* → PC → DVI →

HDMI: HDMI input terminal in AV IN (HDMI).

VIDEO: Video input terminal in VIDEO.

Component\*: Component or RGB input terminal in COMPONENT/RGB IN.

PC: PC input terminal in PC IN.

DVI: DVI input terminal in DVI-D IN.

\* "Component" may be displayed as "RGB" depending on the setting of "COMPONENT/RGB-IN SELECT". (see page 40)

When an optional Terminal Board is installed:

→ HDMI → SLOT INPUT → VIDEO → Component → PC → DVI →

SLOT INPUT: Input terminal in Terminal Board

**Note:**

When a Terminal Board incompatible with the Display is installed, "NON-COMPATIBLE FUNCTION BOARD" is displayed.

When a Terminal Board with dual input terminals is installed:

→ HDMI → SLOT INPUT A → SLOT INPUT B → VIDEO → Component → PC → DVI →

SLOT INPUT A, SLOT INPUT B: Dual input terminal in Terminal Board.



**Notes:**

- Selecting is also possible by pressing the INPUT button on the unit.
- Select to match the signals from the source connected to the component/RGB input terminals. (see page 40)

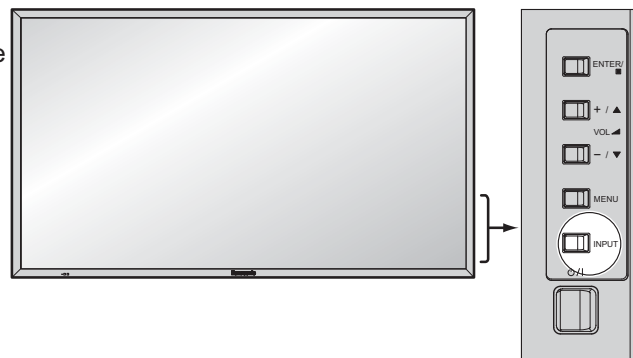

# Basic Controls

## Main Unit

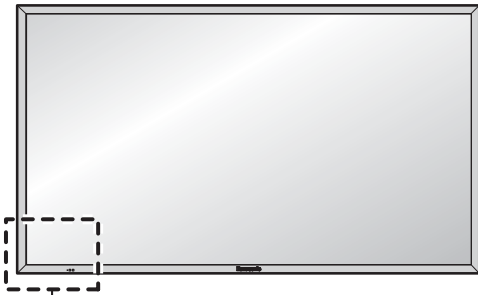

Remote control sensor

### Power Indicator

The Power Indicator will light.

- Power-OFF .... Indicator not illuminated (The unit will still consume some power as long as the power cord is still inserted into the wall outlet.)
- Standby ..... Red  
Orange (When "Slot power" is set to "On". See page 47)  
Orange (Depending on the type of the function board installed, when the power is supplied to the slot)  
Orange (When "CONTROL I/F SELECT" is set to "LAN". See page 45)
- Power-ON ..... Green
- PC POWER MANAGEMENT (DPMS) ..... Orange (With PC input signal. See page 35)
- DVI-D POWER MANAGEMENT ..... Orange (With DVI input signal. See page 35)

### Brightness Sensor

Detects the brightness in the viewing environment.

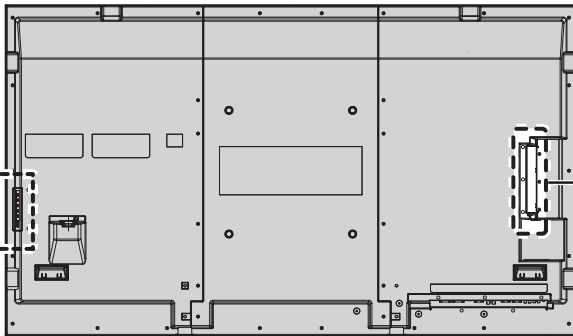

**SLOT:** Terminal board (optional accessories) insert slot (see page 6)

### Note:

The upper side slot is for terminal board with 2-slot width. The terminal board with 1-slot width does not function when installed in the upper side slot.

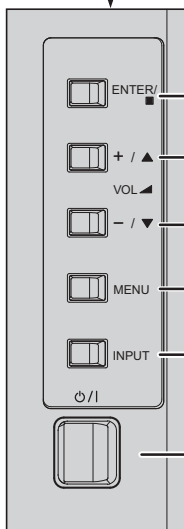

**Enter / Aspect button**  
(see page 22, 24)

### Volume Adjustment

Volume Up "+" Down "-"  
When the menu screen is displayed:  
"+": press to move the cursor up  
"-": press to move the cursor down  
(see page 24)

### MENU Screen ON / OFF

Each time the MENU button is pressed, the menu screen will switch. (see page 24)

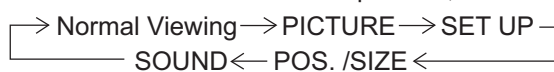

**INPUT button (Input signal selection)** (see page 19)

**Main Power On / Off Switch**

## Remote Control Transmitter

**ACTION button**  
Press to make selections.

**ASPECT button**  
Press to adjust the aspect.  
(see page 22)

**Standby (ON / OFF) button**  
The Display must first be plugged into the wall outlet and turned on at the power switch (see page 17). Press this button to turn the Display On, from Standby mode. Press it again to turn the Display Off to Standby mode.

**POS. /SIZE button**  
(see page 25, 26)

**PICTURE button**  
(see page 27, 28)

**Sound mute On / Off**  
Press this button to mute the sound. Press again to reactivate sound. Sound is also reactivated when power is turned off or volume level is changed.

**N button**  
(see page 26, 27, 28, 29)

**POSITION buttons**

**INPUT button**  
Press to select input signal sequentially.  
(see page 19)

**ECO MODE (ECO)**  
Press to change the ECO MODE setup status. (see page 35)

**FUNCTION buttons (FUNCTION)**  
(see page 48)

### OFF TIMER button

The Display can be preset to switch to stand-by after a fixed period. The setting changes to 30 minutes, 60 minutes, 90 minutes and 0 minutes (off timer cancelled) each time the button is pressed.

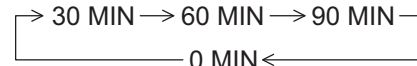

When three minutes remain, "OFF TIMER 3 MIN" will flash.

The off timer is cancelled if a power interruption occurs.

### AUTO SETUP button

Automatically adjusts the position/size of the screen. (see page 25)

**SET UP button** (see page 30 - 45)

**SOUND button** (see page 29)

### Volume Adjustment

Press the Volume Up "+" or Down "-" button to increase or decrease the sound volume level.

**R button** (see page 24)

Press the R button to return to previous menu screen.

### RECALL button

Press the "RECALL" button to display the current system status.

- ① Input label
- ② Aspect mode (see page 22)
- ③ Off timer

The off timer indicator is displayed only when the off timer has been set.

- ④ Clock display (see page 47)

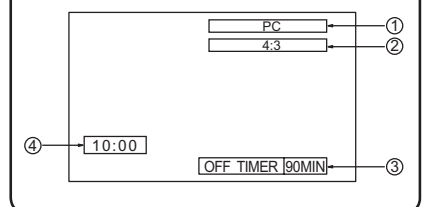

**Digital Zoom** (see page 23)

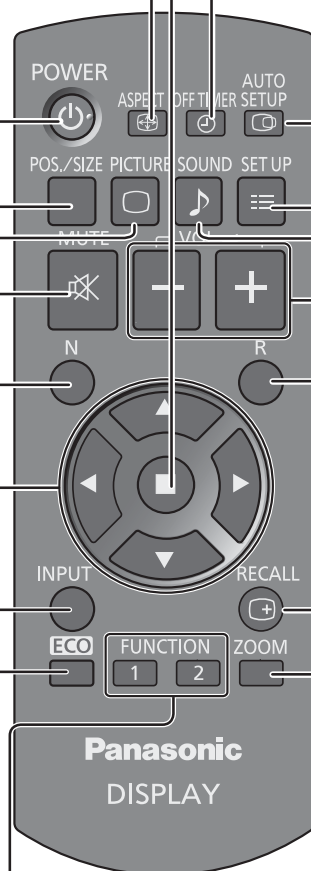

# ASPECT Controls

The Display will allow you to enjoy viewing the picture at its maximum size, including wide screen cinema format picture.

**Note:**

Be aware that if you put the display in a public place for commercial purposes or a public showing and then use the aspect mode select function to shrink or expand the picture, you may be violating the copyright under copyright law. It is prohibited to show or alter the copyrighted materials of other people for commercial purposes without the prior permission of the copyright holder.



Press repeatedly to move through the aspect options:

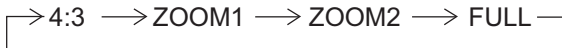

[from the unit]

**Right side surface**

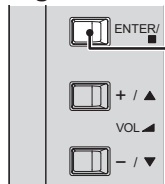

The aspect mode changes each time the ENTER button is pressed.



**Note:**

The aspect mode is memorized separately for each input terminal.

Aspect mode	Picture → Enlarged screen	Description
FULL		The display of the pictures fills the screen. In the case of SD signals, pictures with a 4:3 aspect ratio are enlarged horizontally, and displayed. This mode is suited to displaying anamorphic pictures with a 16:9 aspect ratio.
4:3		Pictures with a 4:3 aspect ratio are displayed with their original aspect ratio. Side panels are displayed at the left and right edges of the screen.  Pictures with a 16:9 aspect ratio are displayed with their original aspect ratio. The left and right edges of the pictures are masked by side panels.
ZOOM1		Letterbox pictures with a 16:9 aspect ratio are enlarged vertically and horizontally so that their display fills the screen. The top and bottom edges of the pictures are cut off.
ZOOM2		Letterbox pictures with a 16:9 aspect ratio are enlarged vertically and horizontally so that their display fills the screen. The top and bottom edges as well as the left and right edges of the pictures are cut off.

# Digital Zoom

This displays an enlargement of the designated part of the displayed image.

## 1 Display the operation guide.

**ZOOM**  
 Press to access Digital Zoom.  
 The operation guide will be displayed.

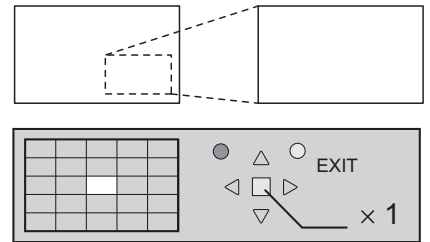

**During Digital Zoom, only the following buttons can be operated.**

[Remote control]

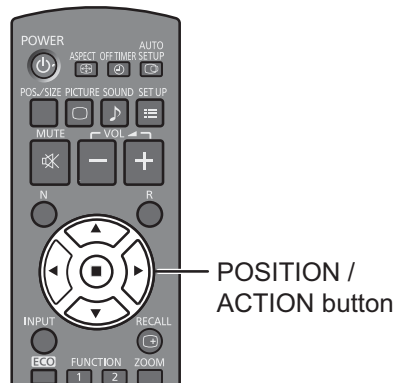

## 2 Select the area of the image to be enlarged.

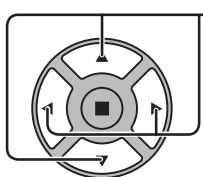
 Press on the enlargement location to select.  
 The cursor will move.

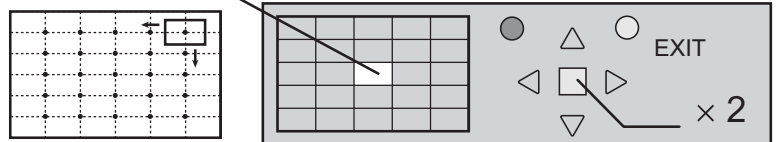

## 3 Select the magnification required for the enlarged display.

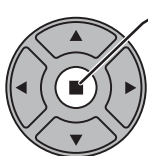
 Each time this is pressed, the magnification factor changes.  
 This is shown in the image being displayed.

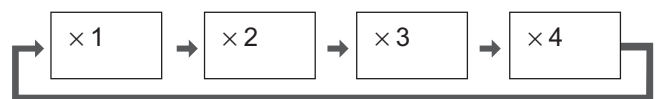

## 4 Return to normal display (quit Digital Zoom).

**R**  
 Press to exit from the Digital Zoom.

### Notes:

- When power goes OFF (including "Off Timer" operation), Digital Zoom terminates.
- The Digital Zoom function cannot be selected while in the following operation state:  
 When MULTI DISPLAY SETUP is ON (see page 38).  
 When SCREENSAVER is running. (see page 32)
- While Digital Zoom is in operation, "Adjusting POS. /SIZE" cannot be used.

# On-Screen Menu Displays

## Remote Control

## Unit

### 1 Display the menu screen.



Press to select.  
(Example: PICTURE menu)



Press several times.

Each time the MENU button is pressed, the menu screen will switch.

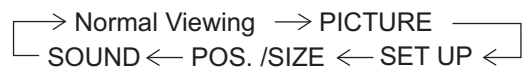

### 2 Select the item.

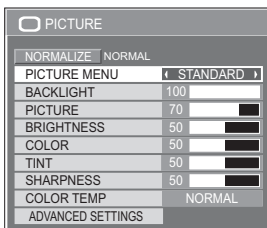

(Example: PICTURE menu)

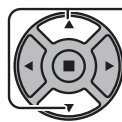

Select.



Press.

Select.

### 3 Set.



Adjust.



Press.

Adjust.

### 4 Exit the menu.



Press.

Press  $\text{\textcircled{R}}$  to return to the previous menu.



Press several times.

## Menu display list

**Note:** Menu that cannot be adjusted is grayout. Adjustable menu changes depending on signal, input and menu setting.

### PICTURE menu

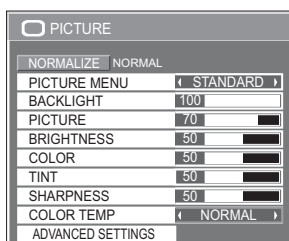

see page 27, 28

### SET UP menu

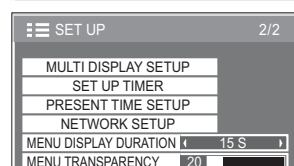
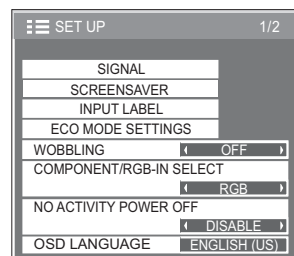

see page 30-45

### POS./SIZE menu

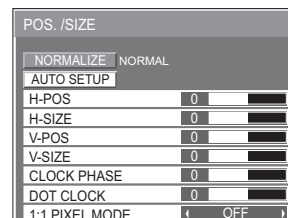

see page 25, 26

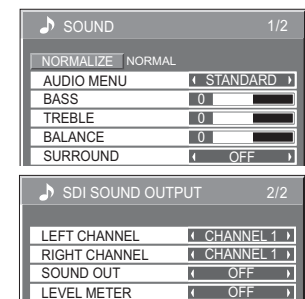

### SOUND menu



see page 29

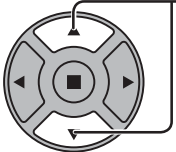
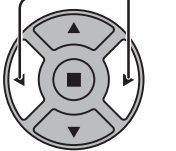

# Adjusting POS. /SIZE

- 1  Press to display the POS. /SIZE menu.
- 2  Press to select the menu to adjust.
- 3  Press to adjust the menu.
- 4  Press to exit from adjust mode.

POS. /SIZE	
NORMALIZE	NORMAL
AUTO SETUP	
H-POS	0
H-SIZE	0
V-POS	0
V-SIZE	0
CLOCK PHASE	0
DOT CLOCK	0
1:1 PIXEL MODE	OFF

## Note:

Unadjustable items are grayed out. Adjustable items differ depending on the input signal and the display mode.

## Note:

If a "Cue" or "Rew" signal from a VCR or DVD player is received, the picture position will shift up or down. This picture position movement cannot be controlled by the POS. /SIZE function.

## AUTO SETUP

H-POS/V-POS, H-SIZE/V-SIZE, DOT CLOCK and CLOCK PHASE are automatically adjusted when the RGB or PC signal is received.

This setting only operates when a PC signal or RGB signal is input, and the aspect is "FULL".

## Using Remote Control



When  on the remote control is pressed, "AUTO SETUP" will be executed.

When AUTO SETUP does not work, "INVALID" is displayed.

## Notes:

- AUTO SETUP may not work when a cropped or dark image is input. In such case, switch to a bright image with borders and other objects are clearly shown, and then try auto setup again.
- Depending on the signal, out of alignment may occur after AUTO SETUP. Carry out fine tuning for the position/size as required.
- If AUTO SETUP cannot set properly for vertical frequency 60Hz XGA signal (1024×768@60Hz and 1366×768@60Hz), pre-selecting the individual signal in "XGA MODE" (see page 42) may results in correct AUTO SETUP.
- AUTO SETUP does not work well when a signal such as additional information is superimposed out of valid image period or intervals between synchronizing and image signals are short.
- If AUTO SETUP cannot adjust correctly, select "NORMALIZE" once and press ACTION (■) then adjust POS. /SIZE manually.
- If the picture goes off screen in the horizontal direction as a result of performing AUTO SETUP, perform DOT CLOCK adjustment.

## Adjusting POS. /SIZE

### H-POS

Adjust the horizontal position.

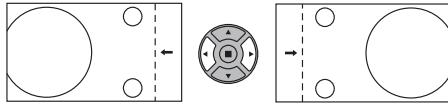

### V-POS

Adjust the vertical position.

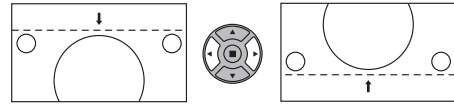

### H-SIZE

Adjust the horizontal size.

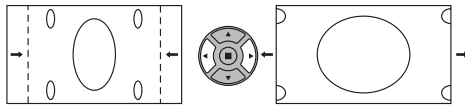

### V-SIZE

Adjust the vertical size.

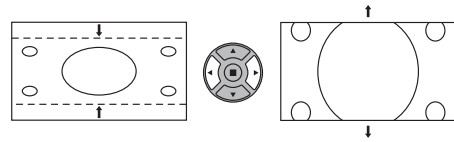

### CLOCK PHASE

**(During RGB and PC input signal)**

Eliminate the flickering and distortion.

### DOT CLOCK

**(During RGB and PC input signal)**

Periodic striped pattern interference (noise) may occur when a striped pattern is displayed. If this happens, adjust so that any such noise is minimized.

### OVER SCAN

Turn image over scan ON/OFF.

Configurable signals are as follows:

525i, 525p, 625i, 625p, 750/60p, 750/50p (Component Video, DVI, HDMI)

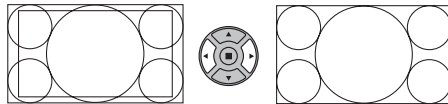

ON

OFF

#### Notes:

- "OFF" is effective during only "FULL" aspect mode.
- When "OFF" is set, "H-SIZE" and "V-SIZE" cannot be adjusted.

**1:1 PIXEL MODE** Adjusts the display size when 1125i or 1125p signal is input.

#### Notes:

- "ON" is effective during only "FULL" aspect mode.
- Select ON when you would like to replay 1920 × 1080 input signal.
- Applicable input signal;  
1125 (1080) / 50i · 60i · 24sF · 24p · 25p · 30p · 50p · 60p
- Select OFF when flickering is shown around the image.
- H-SIZE and V-SIZE cannot be adjusted when ON is selected.

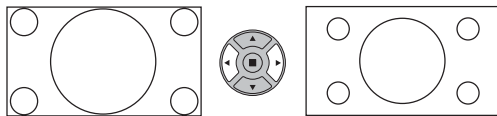

OFF

ON

### Helpful Hint ( / **NORMALIZE** Normalization)

While the POS. /SIZE display is active, if either the N button on the remote control is pressed at any time or the ACTION (  ) button is pressed during "NORMALIZE", then all adjustment values (except "CLOCK PHASE" and "DOT CLOCK") are returned to the factory settings.

# PICTURE Adjustments

**1**  Press to display the PICTURE menu.

**2** Select to adjust each item.

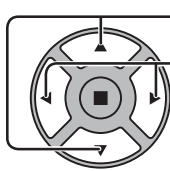
 Press to select the menu to adjust.  
 Select the desired level by looking at the picture behind the menu.

**Note:**  
 Menu that cannot be adjusted is grayout. Adjustable menu changes depending on signal, input and menu setting.

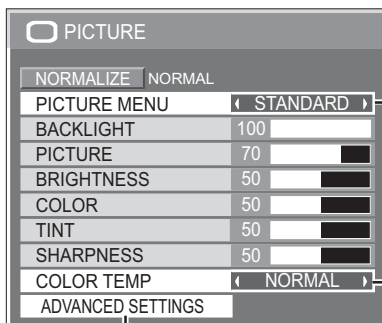

Press the left ◀ or right ▶ button to switch between modes.



**STANDARD**

For viewing in standard (evening lighting) environments.

**DYNAMIC**

For viewing in brighter environments.

**CINEMA**

For use in viewing tone-focused pictures with brightness reduced.

**Note:**

If you would like to change the picture and color of the selected PICTURE menu to something else, adjust using the items in the PICTURE menu. (see next page)

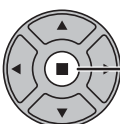
 Press to enter Advanced Settings.

**ADVANCED SETTINGS**  
 Enables fine picture adjustment at a professional level (see next page).

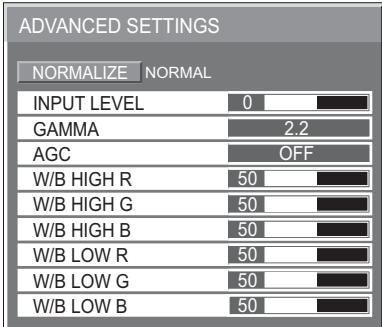

ADVANCED SETTINGS	
NORMALIZE	NORMAL
INPUT LEVEL	0
GAMMA	2.2
AGC	OFF
WB HIGH R	50
WB HIGH G	50
WB HIGH B	50
WB LOW R	50
WB LOW G	50
WB LOW B	50













Press the left ◀ or right ▶ button to switch between modes.



**Helpful Hint (  / NORMALIZE Normalization)**

While the "PICTURE" menu is displayed, if either the N button on the remote control is pressed at any time or the ACTION (■) button is pressed during "NORMALIZE", then all adjustment values are returned to the factory settings.



















## PICTURE Adjustments

Item	Effect	Adjustments
<b>BACKLIGHT</b>	  Darker Brighter	Adjusts luminance of the back light.
<b>PICTURE</b>	  Less More	Adjusts the proper picture contrast.
<b>BRIGHTNESS</b>	  Darker Brighter	Adjusts for easier viewing of dark pictures such as night scenes and black hair.
<b>COLOR</b>	  Less More	Adjusts color saturation.
<b>TINT</b>	  Reddish Greenish	Adjusts for natural flesh tones.
<b>SHARPNESS</b>	  Less More	Adjusts picture sharpness.

### Notes:

- “COLOR” setting can be adjusted for Video input signal.
- You can change the level of each function (BACKLIGHT, PICTURE, BRIGHTNESS, COLOR, TINT, SHARPNESS) for each PICTURE MENU.
- The setting details for STANDARD, DYNAMIC and CINEMA respectively are memorized separately for each input terminal.
- The “TINT” setting can be adjusted for NTSC signal only during Video input signal.
- “BACKLIGHT” can be adjusted when “ECO MODE” is set to “CUSTOM” and “POWER SAVE” to “OFF”. (see page 35)

## ADVANCED SETTINGS

Item	Effect	Details
<b>INPUT LEVEL</b>	  Less More	Adjustment of parts which are extremely bright and hard to see.
<b>GAMMA</b>	  Down Up	S CURVE $\longleftrightarrow$ 2.0 $\longleftrightarrow$ 2.2 $\longleftrightarrow$ 2.6
<b>AGC</b>	  OFF ON	Increases the brightness of dark signal automatically.
<b>W/B HIGH R</b>	  Less More	Adjusts the white balance for light red areas.
<b>W/B HIGH G</b>	  Less More	Adjusts the white balance for light green areas.
<b>W/B HIGH B</b>	  Less More	Adjusts the white balance for light blue areas.
<b>W/B LOW R</b>	  Less More	Adjusts the white balance for dark red areas.
<b>W/B LOW G</b>	  Less More	Adjusts the white balance for dark green areas.
<b>W/B LOW B</b>	  Less More	Adjusts the white balance for dark blue areas.

### Notes:

- Carry out “W/B” adjustment as follows.
  1. Adjust the white balance of the bright sections using the “W/B HIGH R”, “W/B HIGH G” and “W/B HIGH B” settings.
  2. Adjust the white balance of the dark sections using the “W/B LOW R”, “W/B LOW G” and “W/B LOW B” settings.
  3. Repeat steps 1 and 2 to adjust.
 Steps 1 and 2 affect each other’s settings, so repeat each step in turn to make the adjustment.
- The adjustment values are memorized separately for each input terminal.
- The adjustment range values should be used as an adjustment reference.

### Helpful Hint ( / NORMALIZE Normalization)

On the remote control unit, while the “ADVANCED SETTINGS” menu is displayed, if either the N button is pressed at any time or the ACTION (  ) button is pressed during “NORMALIZE”, then all adjustment values are returned to the factory settings.

# SOUND Adjustment

**1**  Press to display the SOUND menu.

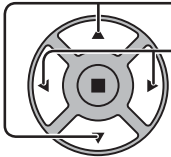
**2** Select to adjust each item.  
 Press to select the menu to adjust.  
 Select the desired level by listening to the sound.

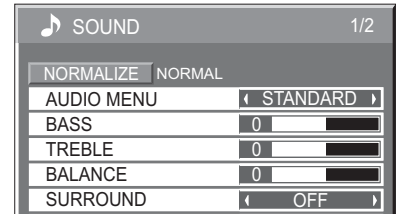

**3**  Press to exit from adjust mode.

Item	Details
<b>AUDIO MENU</b>	<b>STANDARD:</b> Emits the original sound. <b>DYNAMIC:</b> Accentuates sharp sound. <b>CLEAR:</b> Attenuates human voice.
<b>BASS</b>	Adjusts low pitch sounds.
<b>TREBLE</b>	Adjusts high pitch sound.
<b>BALANCE</b>	Adjusts left and right volumes.
<b>SURROUND</b>	Select ON or OFF.

**Note:** BASS, TREBLE and SURROUND settings are memorized separately for each AUDIO MENU.

## Helpful Hint ( / **NORMALIZE** Normalization)

While the "SOUND" menu is displayed, if either the N button on the remote control is pressed at any time or the ACTION () button is pressed during "NORMALIZE", then all adjustment values are returned to the factory settings.

# SDI SOUND OUTPUT

This menu is available only when selecting a slot that the following terminal board is installed:  
 HD-SDI Terminal Board with audio (TY-FB10HD)

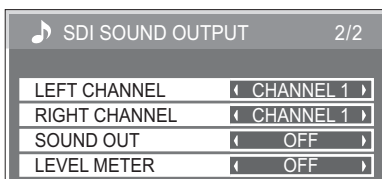



Item	Details
<b>LEFT CHANNEL</b>	<b>CHANNEL 1 to CHANNEL 16</b> Selects left audio channel.
<b>RIGHT CHANNEL</b>	<b>CHANNEL 1 to CHANNEL 16</b> Selects right audio channel.
<b>SOUND OUT</b>	<b>ON</b> $\longleftrightarrow$ <b>OFF</b> <b>ON:</b> Enables audio output. <b>OFF:</b> Disables audio output.
<b>LEVEL METER</b>	<b>OFF</b> $\longleftrightarrow$ <b>1-8CH</b> $\longleftrightarrow$ <b>9-16CH</b> Sets audio channels to show in the audio level meter. 8 channels are displayed in the audio level meter; 4 channels each on both right and left sides of the display. <b>OFF:</b> Hides the audio level meter. <b>1-8CH:</b> Displays the audio level meter (1-8ch) <b>9-16CH:</b> Displays the audio level meter (9-16ch)

# PRESENT TIME SETUP / SET UP TIMER

The timer can switch the Display ON or OFF.

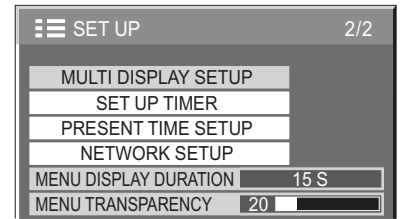
Before attempting Timer Set, confirm the PRESENT TIME OF DAY and adjust if necessary. Then set POWER ON TIME / POWER OFF TIME.

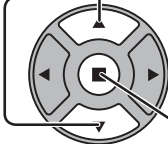

- 1  Press to display the SET UP menu.
- 2  Press to select SET UP TIMER or PRESENT TIME SETUP.  
Press to display the SET UP TIMER screen or PRESENT TIME SETUP screen.

## PRESENT TIME SETUP

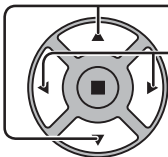
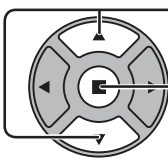
- 1  Press to select DAY or PRESENT TIME OF DAY.  
Press to set up DAY or PRESENT TIME OF DAY.  
▶ button: Forward  
◀ button: Back  
**Notes:**
  - Pressing “◀” or “▶” button once changes PRESENT TIME OF DAY 1 minute.
  - Pressing “◀” or “▶” button continuously changes PRESENT TIME OF DAY by 15 minutes.
- 2  Press to select SET.  
Press to store PRESENT TIME SETUP.  
**Notes:**
  - SET cannot be selected unless PRESENT TIME OF DAY is set.
  - Unless setting the present time other than “99:99”, “DAY” and “PRESENT TIME OF DAY” cannot be set.
  - The settings of “DAY” and “PRESENT TIME OF DAY” are reset when leaving the display turned off for about 7 days for the following reasons:  
Pressing POWER switch of the unit to turn off the display.  
Disconnecting the AC cord.  
Interruption of power supply.

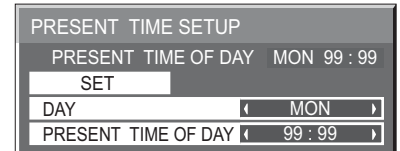

# SET UP TIMER

Set the program for turning the power ON/OFF and select the input signal at the specified time. Up to 20 programs can be set.

**[Setting Example]**

Program 1, Every Monday, 12:00, Power On, Input: VIDEO

SET UP TIMER	
PRESENT TIME OF DAY MON 0 : 03	
PROGRAM	1
TIMER FUNCTION	ON
DAY	MON
POWER MODE	POWER ON
TIME	12 : 00
INPUT	VIDEO

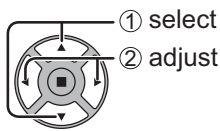

- 1 Set the program number.
- 2 To execute the program, set to "ON".  
The program is disabled when "OFF" is set.
- 3 Set the day.  
The program is executed every day when "EVERYDAY" is set.
- 4 Set the power ON/OFF.
- 5 Set the time.  
Pressing "◀" or "▶" button once changes "TIME" 1 minute.  
Pressing "◀" or "▶" button continuously changes "TIME" by 15 minutes.
- 6 Set the input.

**Notes:**

- This function cannot be set unless "PRESENT TIME SETUP" is set.
- If more than one programs are set for the same time, only the program with the smallest program number is enabled.

# SCREENSAVER (For preventing image retention)

Do not display a still picture, especially in 4:3 mode, for any length of time.

If the display must remain on, a SCREENSAVER should be used.

When the screen saver is operating, the following 5 patterns are displayed full screen for 5 seconds each.

Black→Dark Gray→Gray→Light Gray→White

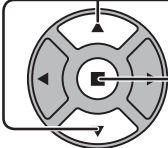
- 1  Press to display the SET UP menu.
- 2  Press to select the SCREENSAVER.  
Press to select the SCREENSAVER screen.

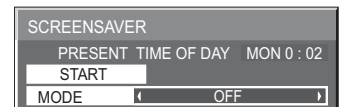
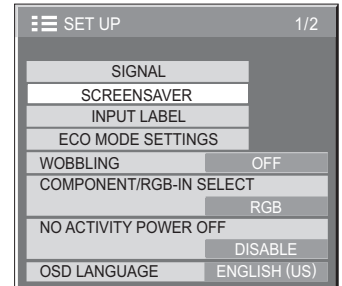

## 3 MODE selection

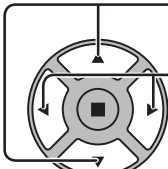
- 3  Press to select the MODE.  
Press to select each mode items.

- Off
- ↕
- INTERVAL : Operates when SHOW DURATION and SAVER DURATION are set up and those times arrive.
- ↕
- TIME OF DAY : Operates when START TIME and FINISH TIME are set up and those times arrive.
- ↕
- STANDBY AFTER SCR SAVER: Operates while SCREENSAVER DURATION, and display enters standby mode.
- ↕
- ON : Operates when START is selected and the ACTION (■) button is pressed.

## 4 START setting

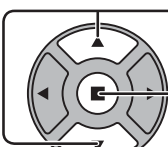
- 4  When the MODE is set to ON, press to select START.  
Press to start SCREENSAVER.

The menu screen will disappear and the SCREENSAVER will be activated. **To stop the SCREENSAVER under ON, press the R button or any buttons on the main unit.**  
**Note:** When the display is turned off, the SCREENSAVER will be deactivated.



## SCREENSAVER (For preventing image retention)

### Setup of SCREENSAVER Time

After selecting TIME OF DAY, INTERVAL or STANDBY AFTER SCR SAVER, the relevant Time Setup will become available for selection and the Operating Time may be set. (Time cannot be set when "MODE" is "ON" or "OFF".)

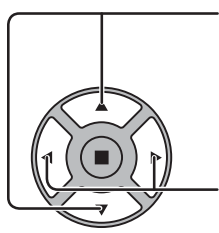

- Press to select START TIME / FINISH TIME (When TIME OF DAY is selected).
- Press to select SHOW DURATION / SAVER DURATION (When INTERVAL is selected).
- Press to select SCREENSAVER DURATION (When STANDBY AFTER SCR SAVER is selected).
- Press to setup.
  - ▶ button: Forward
  - ◀ button: Back

#### Notes:

- Pressing "◀" or "▶" button once changes the Time 1 minute. [However, switching occurs every 15 minutes when Periodic Time is selected.]
- Pressing "◀" or "▶" button continuously changes the Time by 15 minutes.
- "SCREENSAVER DURATION" of the "STANDBY AFTER SCR SAVER" can be set from 0:00 to 23:59. When this is set to "0:00", "STANDBY AFTER SCR SAVER" will not be activated.

**Note:** Timer function will not work unless "PRESENT TIME OF DAY" is set.

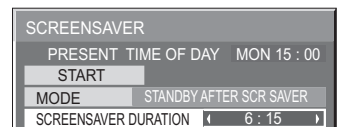
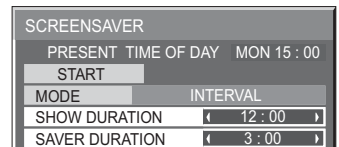
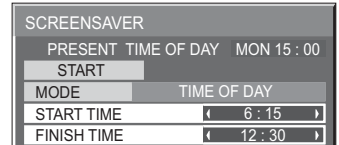

## WOBBLING

Automatically shifts the display image (therefore unnoticeable to the eye) to prevent image retention of sharper contour of image.

1



Press to display the SET UP menu.

2

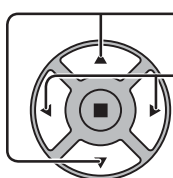

Press to select "WOBBLING".

Press to select "ON" or "OFF".

**ON:** Shifts the position of the display image on a fixed time interval.

3



Press to exit from adjust mode.

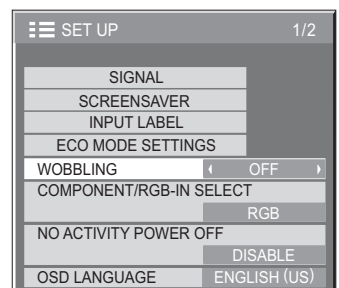

#### Notes:

- If "MULTI DISPLAY SETUP" is set to "ON", this function does not operate.
- When this function is operating, part of the screen may appear to be missing.

# NO ACTIVITY POWER OFF

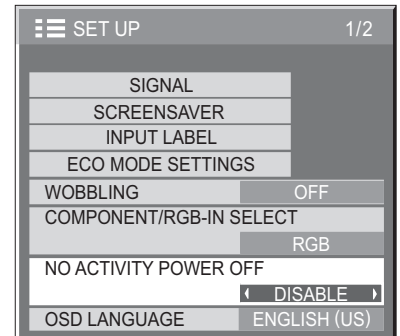
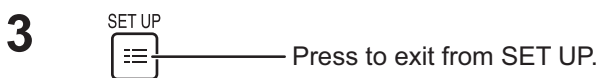
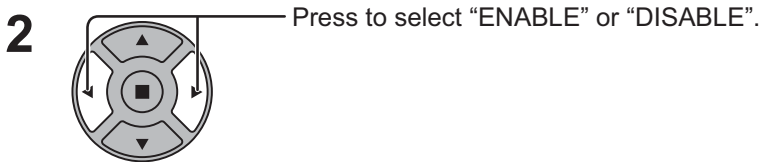
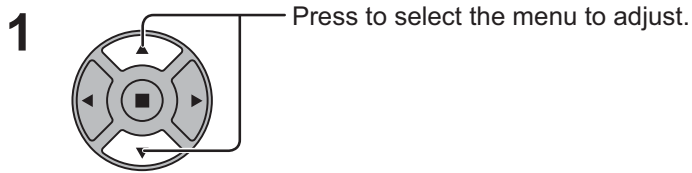

When this function is set to "ENABLE", the power is turned off (standby) automatically when there is no operation of the Display for 4 hours.

Starting from 3 minutes before the turn off, the remaining time will be displayed.



When the power is turned off due to this function, a message "LAST TURN OFF DUE TO 'NO ACTIVITY POWER OFF'." is displayed next time the power is turned on.

**Note:**

During the screensaver is running, this function is disabled.

# ECO MODE SETTINGS

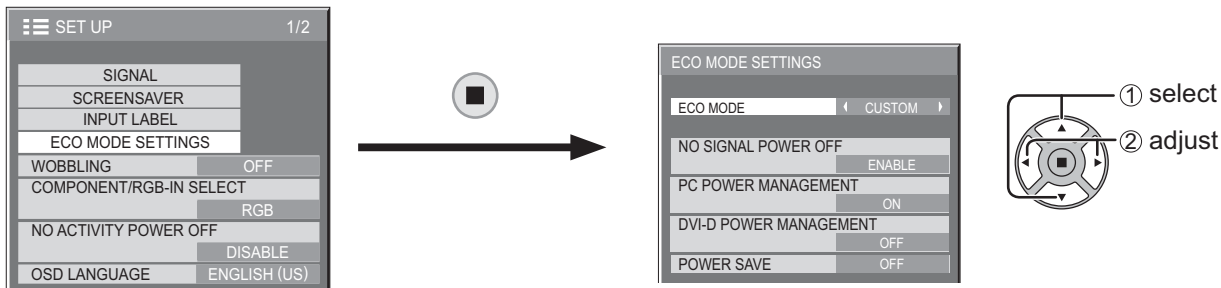

## ECO MODE

**CUSTOM:** The menu of power consumption reduction is individually set.

**ON:** The following fixed values are set to the menu of power consumption reduction. Individual setting is not available.

NO SIGNAL POWER OFF: ENABLE

PC POWER MANAGEMENT: ON

DVI-D POWER MANAGEMENT: ON

POWER SAVE: SENSOR

### Using Remote Control

When **ECO** is pressed, the "ECO MODE" setting changes.

ECO MODE ON

## Custom settings

The menu of the power consumption reduction is individually set. This setting is enabled when "ECO MODE" is set to "CUSTOM".

### NO SIGNAL POWER OFF

Equipment power supply is turned OFF when there is no signal.

When this is set to "ENABLE", the power supply of the unit goes Off 10 minutes after the input signals stop.

#### Note:

This function is effective during normal viewing (one picture screen).

### PC POWER MANAGEMENT

When this function is set to ON, it operates under the following conditions to turn the power on or off automatically.

When no pictures are detected for 30 or so seconds during PC signal input:

→ Power is turned off (standby); the power indicator lights up orange.

When pictures are subsequently detected:

→ Power is turned on; the power indicator lights up green.

#### Notes:

- This function operates only during input from PC IN terminal.

- This function is effective when "SYNC" is set to "AUTO" and during normal viewing (one picture screen).

### DVI-D POWER MANAGEMENT

When this function is set to ON, it operates under the following conditions to turn the power on or off automatically.

When no pictures (sync signal) are detected for 30 or so seconds during DVI signal input:

→ Power is turned off (standby); the power indicator lights up orange.

When pictures (sync signal) are subsequently detected:

→ Power is turned on; the power indicator lights up green.

#### Note:

This function operates only during DVI signal input.

### POWER SAVE

This function adjusts the brightness of the backlight to reduce power consumption.

**OFF:** This function does not operate.

**ON:** Backlight brightness is reduced.

**SENSOR:** The backlight brightness is automatically adjusted according to the viewing environment.

#### Note:

When this function is set to "ON" or "SENSOR", the "BACKLIGHT" setting in the PICTURE menu is disabled.

# Customizing the Input labels

This function can change the label of the Input signal to be displayed. (see page 19)

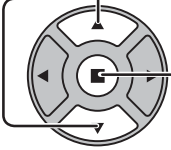
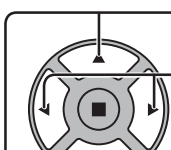
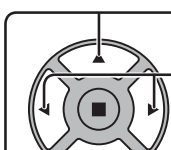
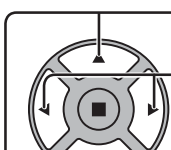
- 1  Press to display the SETUP menu.
- 2  Press to select INPUT LABEL.  
 Press to display the INPUT LABEL screen.
- 3  Press to select image input.  
 Press to change input label.

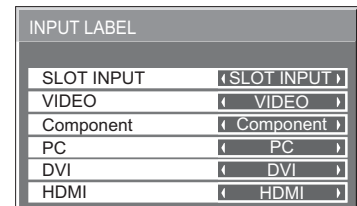
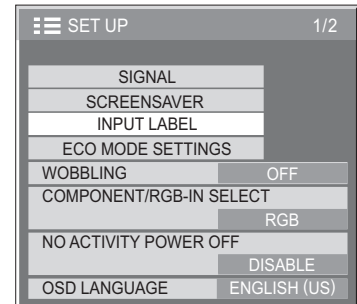

Image input	Input label
[SLOT INPUT]*1	SLOT INPUT / DVD1 / DVD2 / DVD3 / Blu-ray1 / Blu-ray2 / Blu-ray3 / CATV / VCR / STB / (SKIP)
[VIDEO]	VIDEO / DVD1 / DVD2 / DVD3 / Blu-ray1 / Blu-ray2 / Blu-ray3 / CATV / VCR / STB / (SKIP)
[Component]*2	Component / DVD1 / DVD2 / DVD3 / Blu-ray1 / Blu-ray2 / Blu-ray3 / CATV / VCR / STB / (SKIP)
[PC]	PC / DVD1 / DVD2 / DVD3 / Blu-ray1 / Blu-ray2 / Blu-ray3 / CATV / VCR / STB / (SKIP)
[DVI]	DVI / DVD1 / DVD2 / DVD3 / Blu-ray1 / Blu-ray2 / Blu-ray3 / CATV / VCR / STB / (SKIP)
[HDMI]	HDMI / DVD1 / DVD2 / DVD3 / Blu-ray1 / Blu-ray2 / Blu-ray3 / CATV / VCR / STB / (SKIP)

(SKIP) : The INPUT button press will skip its input.

\*1 "SLOT INPUT" is displayed when a Terminal Board is installed.

\*2 "Component" may be displayed as "RGB" depending on the setting of "COMPONENT/RGB-IN SELECT".  
(see page 40)

## When a Terminal Board with dual input terminals is installed

"SLOT INPUT" is displayed as "SLOT INPUT A" and "SLOT INPUT B" and independent settings are available.

[SLOT INPUT A]	SLOT INPUT A / DVD1 / DVD2 / DVD3 / Blu-ray1 / Blu-ray2 / Blu-ray3 / CATV / VCR / STB / (SKIP)
[SLOT INPUT B]	SLOT INPUT B / DVD1 / DVD2 / DVD3 / Blu-ray1 / Blu-ray2 / Blu-ray3 / CATV / VCR / STB / (SKIP)

# Selecting the On-Screen Menu Language

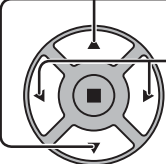
-  Press to display the SET UP menu.
- 
  - Press to select OSD LANGUAGE.
  - Press to select your preferred language.

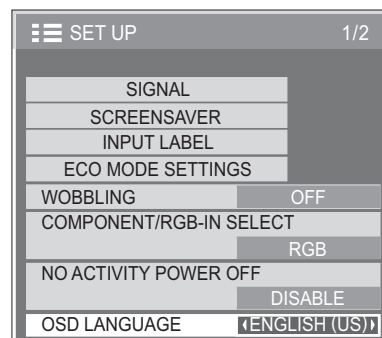

## ■ Selectable languages

- English (UK)
- ↕
- Deutsch
- ↕
- Français
- ↕
- Italiano
- ↕
- Español
- ↕
- ENGLISH (US)
- ↕
- 中文.....(Chinese)
- ↕
- 日本語.....(Japanese)
- ↕
- Русский.....(Russian)

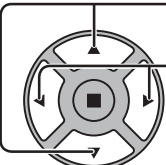
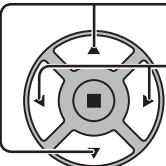

# Customizing the On-Screen Menu Display

Set the display time and background transparency of the on-screen menu display.

-  Press to display the SET UP menu.
- 
  - Press to select "MENU DISPLAY DURATION".
  - Press to adjust the display duration.
- 
  - Press to select "MENU TRANSPARENCY".
  - Press to adjust the transparency.
-  Press to exit from adjust mode.

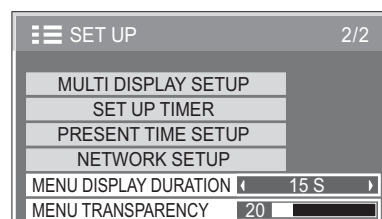

# SET UP for MULTI DISPLAY

By lining up the Displays in groups, for example, as illustrated below, an enlarged picture may be displayed across all screens.

For this mode of operation, each display has to be set up with a Display number to determine its location.

(Example)

group of 4 (2 × 2)



group of 9 (3 × 3)





group of 16 (4 × 4)



group of 25 (5 × 5)

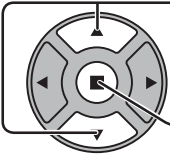

## How to setup MULTI DISPLAY

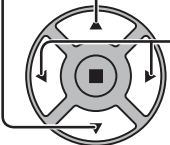
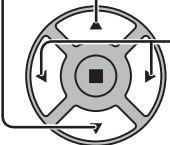
- 1  Press to display the SET UP menu.
- 2  Press to select the MULTI DISPLAY SETUP.  
 Press to display the "MULTI DISPLAY SETUP" menu.
- 3  Press to select the MULTI DISPLAY SETUP.  
 Press to select "ON" or "OFF".

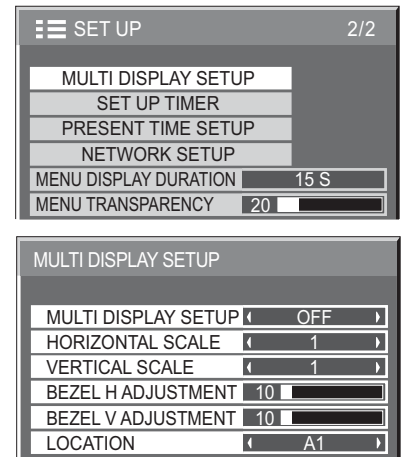

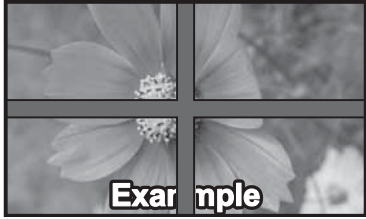
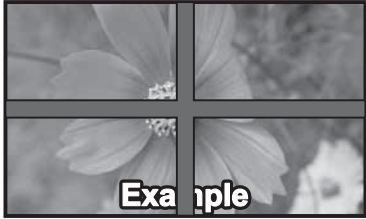
Item	Details
<b>MULTI DISPLAY SETUP</b>	Select "ON" or "OFF".
<b>HORIZONTAL SCALE</b>	Select "1", "2", "3", "4", "5".
<b>VERTICAL SCALE</b>	Select "1", "2", "3", "4", "5".
<b>BEZEL H ADJUSTMENT</b> <b>BEZEL V ADJUSTMENT</b>	<p>Areas of the image that are hidden by the joint sections are adjusted both horizontally and vertically (0~100).</p> <div style="display: flex; justify-content: space-around;"> <div style="text-align: center;"> <p>To show joints between displays.</p>  <p><b>Example</b></p> <p>Suitable for still image display. Setting value: 0</p> </div> <div style="text-align: center;"> <p>To hide joints between displays.</p>  <p><b>Example</b></p> <p>Suitable for moving image display. Setting value: 100</p> </div> </div>

## SET UP for MULTI DISPLAY

Item	Details																																																									
LOCATION	<p>Select the required arrangement number. (A1-E5 : Refer to the following)</p> <p><b>Display Number locations for each arrangement.</b>  <b>(Examples)</b></p> <p>( 2 × 1 )    ( 2 × 3 )    ( 4 × 2 )    ( 4 × 4 )    ( 5 × 5 )</p> <table style="display: inline-table; margin-right: 10px;"> <tr><td>A1</td><td>A2</td></tr> </table> <table style="display: inline-table; margin-right: 10px;"> <tr><td>A1</td><td>A2</td></tr> <tr><td>B1</td><td>B2</td></tr> <tr><td>C1</td><td>C2</td></tr> </table> <table style="display: inline-table; margin-right: 10px;"> <tr><td>A1</td><td>A2</td><td>A3</td><td>A4</td></tr> <tr><td>B1</td><td>B2</td><td>B3</td><td>B4</td></tr> </table> <table style="display: inline-table; margin-right: 10px;"> <tr><td>A1</td><td>A2</td><td>A3</td><td>A4</td></tr> <tr><td>B1</td><td>B2</td><td>B3</td><td>B4</td></tr> <tr><td>C1</td><td>C2</td><td>C3</td><td>C4</td></tr> <tr><td>D1</td><td>D2</td><td>D3</td><td>D4</td></tr> </table> <table style="display: inline-table;"> <tr><td>A1</td><td>A2</td><td>A3</td><td>A4</td><td>A5</td></tr> <tr><td>B1</td><td>B2</td><td>B3</td><td>B4</td><td>B5</td></tr> <tr><td>C1</td><td>C2</td><td>C3</td><td>C4</td><td>C5</td></tr> <tr><td>D1</td><td>D2</td><td>D3</td><td>D4</td><td>D5</td></tr> <tr><td>E1</td><td>E2</td><td>E3</td><td>E4</td><td>E5</td></tr> </table>	A1	A2	A1	A2	B1	B2	C1	C2	A1	A2	A3	A4	B1	B2	B3	B4	A1	A2	A3	A4	B1	B2	B3	B4	C1	C2	C3	C4	D1	D2	D3	D4	A1	A2	A3	A4	A5	B1	B2	B3	B4	B5	C1	C2	C3	C4	C5	D1	D2	D3	D4	D5	E1	E2	E3	E4	E5
A1	A2																																																									
A1	A2																																																									
B1	B2																																																									
C1	C2																																																									
A1	A2	A3	A4																																																							
B1	B2	B3	B4																																																							
A1	A2	A3	A4																																																							
B1	B2	B3	B4																																																							
C1	C2	C3	C4																																																							
D1	D2	D3	D4																																																							
A1	A2	A3	A4	A5																																																						
B1	B2	B3	B4	B5																																																						
C1	C2	C3	C4	C5																																																						
D1	D2	D3	D4	D5																																																						
E1	E2	E3	E4	E5																																																						







- 4**  Press to exit from adjust mode.

## ID Remote Control Function

You can set the remote control ID when you want to use this remote control on one of several different displays.

### Note:

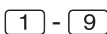
To operate this function, please purchase ID remote controller sold separately.  
 Object model : EUR7636070R

- 1** Switch  to  on the right side.
- 2** Press the  button on the remote control.
- 3** Press one of ,  for the tens digit setting.
- 4** Press one of ,  for the units digit setting.

### Notes:

- The numbers in 2, 3 and 4 should be set up quickly.
- Adjustable ID number range is 0 - 99.
- If a number button is pressed more than two times, the first two numbers become the ID number for the remote control.

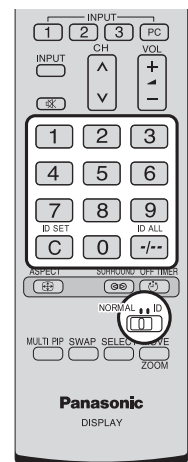

### ID remote control button operation

The operation is the same as normal remote control except for the  button.

### ID Cancellation

Press  button on remote control. (This has the same effect as pressing the , ,  buttons at the same time.)

### Notes:

- Set the Remote ID "On" to operate the ID remote control.  
 If Remote ID is set to "On", you can use the remote control without identical ID number during option menu display. (see page 47)
- The ID remote control cannot be used when ID select is set to anything other than 0, and the remote control ID is not the same as the ID select number (see page 47).

# SET UP for Input Signals

## COMPONENT / RGB IN SELECT

Select to match the signals from the source connected to the COMPONENT/RGB IN terminal.

Y, P<sub>B</sub>, P<sub>R</sub> signals ⇔ "COMPONENT"

RGB signals ⇔ "RGB"

**1**  Press to display the SET UP menu.

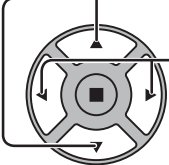
**2**  Press to select the "COMPONENT / RGB-IN SELECT".  
Press to select the desired mode.  
COMPONENT ← → RGB

**3**  Press to exit from adjust mode.

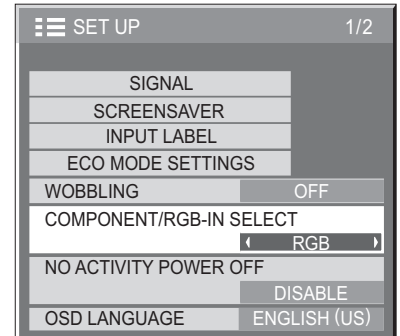

### Note:

Make setting of the selected input terminal (COMPONENT/RGB IN).

## YUV / RGB IN SELECT

Select to match the signals from the source connected to DVI-D IN terminal.

YUV signals ⇔ "YUV"

RGB signals ⇔ "RGB"

**1**  Press to display the SET UP menu.

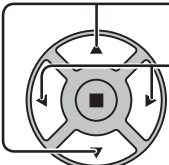
**2**  Press to select the "YUV / RGB-IN SELECT".  
Press to select the desired mode.  
YUV ← → RGB

**3**  Press to exit from adjust mode.

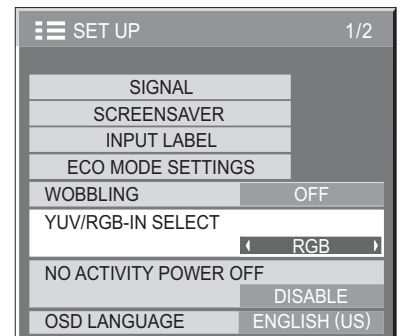



## SIGNAL menu

**Note:**

“SIGNAL” setup menu displays a different setting condition for each input signal.

**1**  Press to display the SET UP menu.

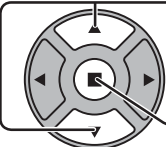
**2**  Press to select the “SIGNAL”.  
Press to display the SIGNAL menu.

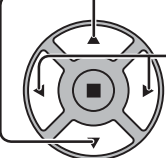
**3**  Press to select the menu to adjust.  
Press to adjust the menu.

**4**  Press to exit from adjust mode.

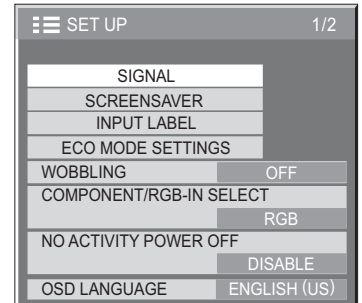

↓ Press ACTION (■) button

**For VIDEO**

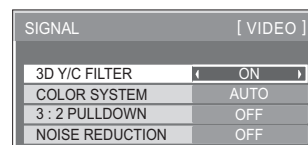

**For RGB**

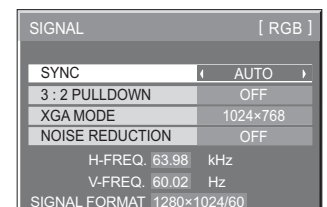

**For COMPONENT**

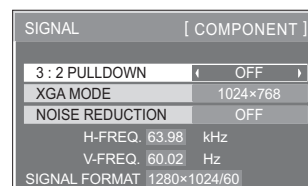

**For Digital**

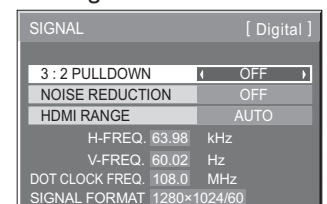

## 3D Y/C FILTER

Select “SIGNAL” from the “SET UP” menu during Video input signal mode. (“SIGNAL [VIDEO]” menu is displayed.)

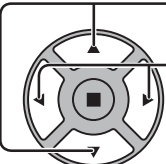
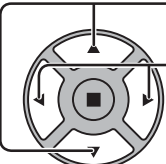
 Press to select the “3D Y/C FILTER”.  
 Press to set ON / OFF.



## SET UP for Input Signals

### COLOR SYSTEM

Select SIGNAL from the "SET UP" menu during Video input signal mode.  
( "SIGNAL [VIDEO]" menu is displayed.)

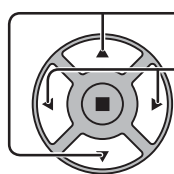

Press to select the "COLOR SYSTEM".

Press to select each function.

**If the image becomes unstable:**

With the system set on Auto, under conditions of low level or noisy input signals the image may in rare cases become unstable. Should this occur, set the system to match the format of the input signal.

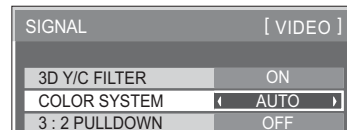

**COLOR SYSTEM:** Set the color system to match the input signal. When "AUTO" is set, COLOR SYSTEM will be automatically selected from NTSC/PAL/SECAM/NTSC 4.43/PAL M/PAL N.  
To display PAL60 signal, select "AUTO".

→AUTO←→PAL←→SECAM←→NTSC←→NTSC 4.43←→PAL M←→PAL N←

### 3:2 PULLDOWN

**3:2 PULLDOWN:** When ON, the display attempts to reproduce a more natural interpretation of sources such as movie pictures, which are recorded at 24 frames per second.  
If the picture is not stable, turn the setting to OFF.

**Note:**

When ON, this setting only affects the following signal input:

- NTSC / PAL signal input during Video input signal.
- 525i(480i), 625i(575i), 1125(1080)/60i signal input during Component input signal.

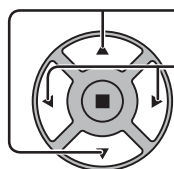

Press to select "3:2 PULLDOWN".

Press to set ON/OFF.



### XGA MODE

This menu is displayed when the input signal is analog (Component/PC).

This menu sets two types of XGA signals with 60Hz vertical frequency having different aspect ratios and sampling rates (1,024 × 768 @ 60Hz and 1,366 × 768 @ 60Hz).

When a 1,280 × 768 @ 60Hz input signal is automatically detected, the image is processed as a 1,280 × 768 @ 60Hz XGA input signal irrespective of this setting.

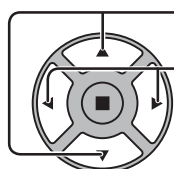

Press to select "XGA MODE".

Press to select "1024×768", "1366×768".



**Note:**

After making this setting, be sure to make each adjustment (such as "AUTO SETUP") on the "POS. /SIZE" menu as necessary. (see page 25, 26)

## NOISE REDUCTION

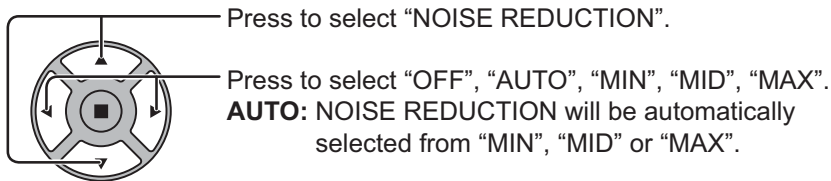

**Note:**

NOISE REDUCTION can be adjusted while a Video or Component signal is being applied.

## SYNC

This function operates only during input from PC IN terminal.

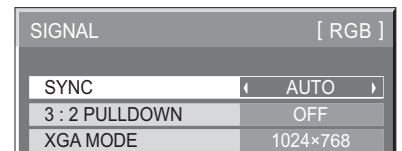
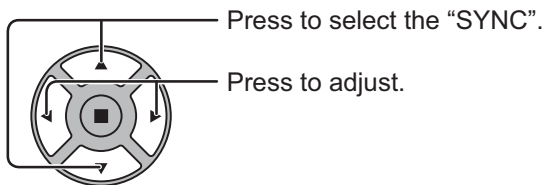

Confirm that the input is set to RGB input (this setting is valid only for RGB input signal).

**AUTO:** The H and V sync or synchronized signal is automatically selected. If both input, it is selected the H and V sync. However, the synchronized signal that is input first is selected.



**ON G:** Uses a synchronized signal on the Video G signal, which is input from the G connector.

**Note:**

Accepts only RGB signals from COMPONENT/RGB IN terminal with "SYNC ON G".

## HDMI RANGE

Switches the dynamic range according to the input signal from HDMI terminal.

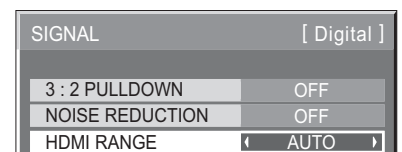
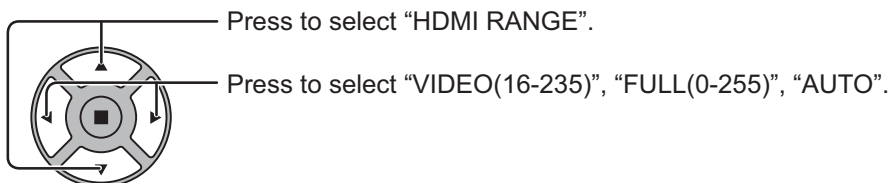

**VIDEO(16-235):** If the input signal is the video range, Example: HDMI terminal output for DVD player

**FULL(0-255):** If the input signal is full range, Example: HDMI terminal output for personal computer

**AUTO:** Switches the dynamic range automatically between "VIDEO(16-235)" and "FULL(0-255)" according to the input signal.

**Note:**

This function can be set only for HDMI signal input.

## SET UP for Input Signals

---

### Input signal display

---

**Displays the frequency and the type of the current input signal.**

This display is valid only for COMPONENT/RGB/PC and Digital input signal.

Display range:

Horizontal 30 - 110 kHz

Vertical 48 - 120 Hz

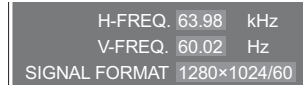

```
H-FREQ. 63.98 kHz
V-FREQ. 60.02 Hz
SIGNAL FORMAT 1280x1024/60
```

The dot clock frequency is displayed during digital signal input.

**Note:**

The automatically detected signal format may be displayed differently than the actual input signal.

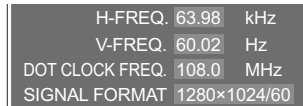

```
H-FREQ. 63.98 kHz
V-FREQ. 60.02 Hz
DOT CLOCK FREQ. 108.0 MHz
SIGNAL FORMAT 1280x1024/60
```

# Network Setup

Make the various settings to use the network function.

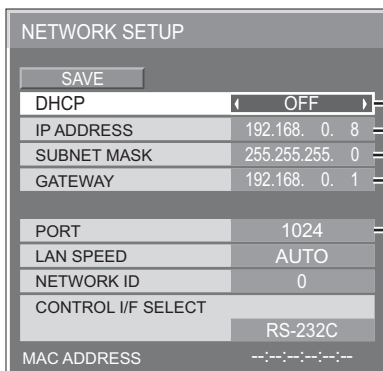
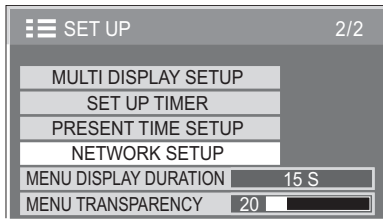

## DHCP, IP ADDRESS, SUBNET MASK, and GATEWAY settings

**1** Set DHCP.  
When “OFF” is selected, IP ADDRESS and other settings can be set manually.

**2** Select the item and press .

**3** Enter an address.

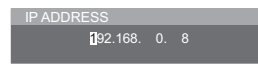

- ① Use to select a digit.
- ② Use to change a number.
- ③ Press .

Pressing will cancel the address change.

**4** Select “SAVE” and press .

## PORT setting

**1** Select “PORT” and press .

**2** Enter a port number.



- ① Use to select a digit.
- ② Use to change a number.
- ③ Press .

Pressing will cancel the port number change.

## SAVE

Save the current network Setup. Each value set for DHCP, IP address, Subnet mask, and Gateway will be saved. If “NG” is displayed, check the same IP address is not used within the same network.

## DHCP (DHCP client function)

To obtain an IP address automatically using a DHCP server, set this to “ON”. If DHCP server is not used, set this to “OFF”.

## IP ADDRESS (IP address display and setting)

Enter an IP address if DHCP server is not used.

## SUBNET MASK (Subnet mask display and setting)

Enter a subnet mask if DHCP server is not used.

## GATEWAY (Gateway address display and setting)

Enter a gateway address if DHCP server is not used.

## PORT

Set the port number used for command control.

The available setting range is 1024 – 65535.

When the PJLink™ protocol is used, the port setting is not necessary.

## LAN SPEED

Set the connection speed of the LAN environment.

Select the value from AUTO, 10 HALF, 10 FULL, 100 HALF or 100 FULL.

## NETWORK ID

Set the ID to identify this unit.

The available setting range is 0 – 99.

## CONTROL I/F SELECT

Set whether to control with RS-232C (serial) or LAN. When “LAN” is set, power indicator lights orange under the condition of power off with remote control (stand-by state).



## MAC ADDRESS

Display the MAC address of this unit. However, the MAC address is not displayed when the “CONTROL I/F SELECT” is set to “RS-232C”.

## Notes:

- To use a DHCP server, make sure the DHCP server is started.
- Contact your network administrator for details on settings.

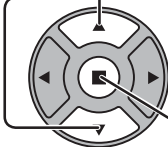
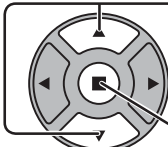
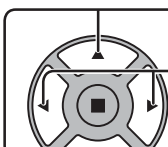
# Options Adjustments

- 1  Press to display the SET UP menu.
- 2  Press to select "OSD LANGUAGE".  
Press for more than 3 seconds.
- 3  Press to select "Options".  
Press to display the Options menu.
- 4  Press to select your preferred menu.  
Press to adjust the menu.
- 5  Press to exit from Options menu.





Options 1/3	
Input Search	
On screen display	← On →
Initial input	← Off →
Initial VOL level	← Off 0 →
Maximum VOL level	← Off 0 →
Input lock	← Off →
Button lock	← Off →
Remocon User level	← Off →





























Options 2/3	
Off-timer function	Enable →
Initial Power Mode	← Normal →
ID select	← 0 →
Remote ID	← Off →
Serial ID	← Off →
Serial Daisy Chain	← --- →
Studio W/B	← Off →

Options 3/3	
Slot power	← Off →
Power ON Screen Delay	← Off →
Clock Display	← Off →
Power On Message (No activity power off)	← On →
Function button assign 1	← Signal →
Function button assign 2	← Screensaver →
Power Switch Lock	← Off →

Item	Adjustments
<b>Input Search</b>	Set auto input switching for when there is no signal. (see page 48)
<b>On screen display</b>	<p><b>On:</b> Displays all the following on screen.</p> <ul style="list-style-type: none"> <li>• Power on display</li> <li>• Input signal switch display</li> <li>• No signal display</li> <li>• Mute and the remaining time of off-timer after  was pressed.</li> </ul> <p><b>Off:</b> Hides all the items above from view.</p>
<b>Initial input</b>	<p>Adjusts the input signal when the unit is turned on.  <b>Off ↔ SLOT INPUT* ↔ VIDEO ↔ Component/RGB ↔ PC ↔ DVI ↔ HDMI ↔ Off</b>            * "SLOT INPUT" is displayed when an optional Terminal Board is installed.            When a Terminal Board with dual input terminals is installed, "SLOT INPUT A" and "SLOT INPUT B" are displayed.</p> <p><b>Notes:</b></p> <ul style="list-style-type: none"> <li>• Only the adjusted signal is displayed. (see page 19)</li> <li>• This menu is available only when "Input lock" is "Off".</li> </ul>
<b>Initial VOL level</b>	<p>Press  button to adjust the volume when the unit is turned on.</p> <p><b>Off ↔ On</b></p> <p><b>Off:</b> Sets normal volume.  <b>On:</b> Sets your preferred volume.</p> <p><b>Notes:</b></p> <ul style="list-style-type: none"> <li>• When "Maximum VOL level" is "On", the volume can only be adjusted between 0 and your maximum range.</li> <li>• You can hear the changed volume regardless of your volume setting before opening the options menu if you adjust the volume when "Initial VOL level" is "On" and cursor is on the menu.</li> </ul>
<b>Maximum VOL level</b>	<p>Press  button to adjust the maximum volume.</p> <p><b>Off ↔ On</b></p> <p><b>Off:</b> Sets auto maximum volume.  <b>On:</b> Sets your preferred maximum volume.</p> <p><b>Notes:</b></p> <ul style="list-style-type: none"> <li>• If the "Maximum VOL level" is set lower than the "Initial VOL level", the "Initial VOL level" automatically becomes the same as the "Maximum VOL level".</li> <li>• The volume display can go up to 100 regardless of the settings.</li> <li>• You can hear the changed volume regardless of your volume setting before opening the options menu if you adjust the volume when "Maximum VOL level" is "On" and cursor is on the menu.</li> </ul>
<b>Input lock</b>	<p>Locks the input switch operation.  <b>Off ↔ SLOT INPUT* ↔ VIDEO ↔ Component/RGB ↔ PC ↔ DVI ↔ HDMI ↔ Off</b>            * "SLOT INPUT" is displayed when an optional Terminal Board is installed.            When a Terminal Board with dual input terminals is installed, "SLOT INPUT A" and "SLOT INPUT B" are displayed.</p> <p><b>Notes:</b></p> <ul style="list-style-type: none"> <li>• Only the adjusted signal is displayed (see page 19).</li> <li>• Input switch can be used when this is set to "Off".</li> </ul>

## Options Adjustments

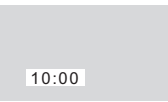

Item	Adjustments
<b>Button lock</b>	<p><b>Off</b> <math>\longleftrightarrow</math> <b>On</b> <math>\longleftrightarrow</math> <b>MENU&amp;ENTER</b></p> <p><b>Off:</b> All the buttons on main unit can be used.</p> <p><b>MENU&amp;ENTER:</b> Locks  MENU and  ENTER buttons on main unit.</p> <p><b>On:</b> Locks all the button on main unit except the Power switch.</p> <p>Sets Button lock with the unit buttons in the following procedure.</p> <p><b>Off:</b> Press  + / <math>\blacktriangle</math> four times <math>\rightarrow</math> Press  INPUT four times <math>\rightarrow</math> Press  - / <math>\blacktriangledown</math> four times <math>\rightarrow</math> Press  ENTER/</p> <p><b>MENU&amp;ENTER:</b> Press  ENTER/ four times <math>\rightarrow</math> Press  + / <math>\blacktriangle</math> four times <math>\rightarrow</math> Press  INPUT four times <math>\rightarrow</math> Press  ENTER/</p> <p><b>On:</b> Press  - / <math>\blacktriangledown</math> four times <math>\rightarrow</math> Press  ENTER/ four times <math>\rightarrow</math> Press  + / <math>\blacktriangle</math> four times <math>\rightarrow</math> Press  ENTER/</p>
<b>Remocon User level</b>	<p><b>Off</b> <math>\longleftrightarrow</math> <b>User1</b> <math>\longleftrightarrow</math> <b>User2</b> <math>\longleftrightarrow</math> <b>User3</b></p> <p><b>Off:</b> You can use all of the buttons on the remote control.</p> <p><b>User1:</b> You can only use , , , , , ,  buttons on the remote control.</p> <p><b>User2:</b> You can only use  button on the remote control.</p> <p><b>User3:</b> Locks all the buttons on remote control.</p>
<b>Off-timer function</b>	<p><b>Enable:</b> Enables the "Off-timer function".</p> <p><b>Disable:</b> Disables the "Off-timer function".</p> <p><b>Note:</b> When "Disable" is set, the Off-timer is cancelled.</p>
<b>Initial Power Mode</b>	<p><b>Normal</b> <math>\longleftrightarrow</math> <b>On</b> <math>\longleftrightarrow</math> <b>Standby</b></p> <p>Sets the power mode of the unit for when the power recovers from failure or after plugging off and in again.</p> <p><b>Normal:</b> Power returns in as the same state as before the power interruption.</p> <p><b>Standby:</b> Power returns in standby mode. (Power Indicator : red/orange)</p> <p><b>On:</b> Power returns in power On. (Power Indicator : green)</p> <p><b>Note:</b> When using multiple displays, "Standby" is preferred to be set in order to reduce a power load.</p>
<b>ID select</b>	<p>Sets panel ID number when panel is used in "Remote ID" or "Serial ID".</p> <p>Set value range: 0 - 100 (Standard value: 0)</p>
<b>Remote ID</b>	<p>The setting of this menu is valid only when using ID remote control.</p> <p><b>Off:</b> Disables ID remote control functions. You can use normal remote control operations.</p> <p><b>On:</b> Enable ID remote control functions.</p> <p><b>Note:</b> To use the ID remote control function, it is necessary to set each ID number of remote control and display unit. About the setting method, please refer to "ID Remote Control Function" (see page 39) and "ID select" (above-mentioned).</p>
<b>Serial ID</b>	<p>Sets the panel ID Control.</p> <p><b>Off:</b> Disables external control by the ID.</p> <p><b>On:</b> Enables the external control by the ID.</p>
<b>Serial Daisy Chain</b>	<p>Sets the top and end of a daisy chain when the SERIAL terminal of Display is daisy chained.</p> <p>---: When the Display is under SERIAL control on a standalone basis, or if not at the top or end of daisy chain.</p> <p><b>Top:</b> To connect to the top of daisy chain.</p> <p><b>End:</b> To connect to the end of daisy chain.</p>
<b>Studio W/B</b>	<p><b>Off:</b> Nullify all the settings adjusted.</p> <p><b>On:</b> Sets the color temperature for TV studio.</p> <p><b>Note:</b> Valid only when the "WARM" is set as "COLOR TEMP" in PICTURE menu.</p>
<b>Slot power</b>	<p><b>Off</b> <math>\longleftrightarrow</math> <b>Auto</b> <math>\longleftrightarrow</math> <b>On</b></p> <p><b>Off:</b> Power is not transmitted to the slot power.</p> <p><b>Auto:</b> Power is transmitted to the slot power only when main power is on.</p> <p><b>On:</b> Power is transmitted to the slot power when main power is on or in the standby state.</p> <p><b>Note:</b> In some cases, power is transmitted to the slot power when main power is on or in the standby state regardless of the slot power setting.</p>
<b>Power ON Screen Delay</b>	<p><b>Off</b> <math>\leftrightarrow</math> <b>1</b> <math>\leftrightarrow</math> <b>2</b> <math>\leftrightarrow</math> <b>3...</b> <math>\leftrightarrow</math> <b>30</b></p> <p>You can set the power-on delay time of the displays to reduce the power load, when you press  /  to turn on the multiple displays that are set together, for example, on MULTI DISPLAY system.</p> <p>Set each display's setting individually.</p> <p><b>Off:</b> The display will be turned on at the same time as  /  is pressed.</p> <p><b>1 to 30 (sec.):</b> Set the power-on delay time (second).</p> <p>After pressing  / , the display will be powered on with time delay depending on this setting.</p> <p><b>Notes:</b></p> <ul style="list-style-type: none"> <li>• During this function is working, the power indicator is blinking green.</li> <li>• This function also works when the power recovers from failure or after plugging off and in again the power cord.</li> </ul>
<b>Clock Display</b>	<p><b>Off:</b> Not display the clock.</p> <p><b>On:</b> Display the clock.</p> <p>The clock is displayed at the lower left of the screen when  button is pressed.</p> <p><b>Note:</b> When "PRESENT TIME SETUP" is not set, the clock is not displayed even if "Clock Display" is "On" (see page 30)</p> <div style="text-align: center; margin-top: 10px;">  </div>

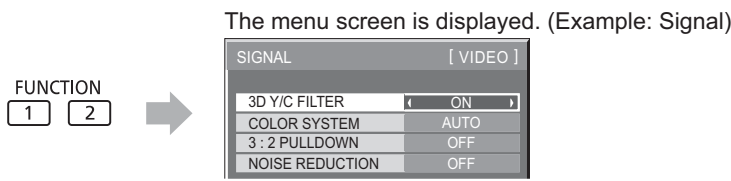
## Options Adjustments

Item	Adjustments
<b>Power On Message (No activity power off)</b>	Whether to show/hide No activity power off Precautions at the time of power ON is set. <b>On:</b> The warning precautions are shown at the time of power ON. <b>Off:</b> The warning precautions are not shown at the time of power ON. <b>Note:</b> This setting is enabled only if "NO ACTIVITY POWER OFF" is "ENABLE" (see page 34).
<b>Function button assign 1 Function button assign 2</b>	Set the functions that operates when  is pressed. <b>Signal:</b> The "SIGNAL" menu is displayed. <b>Screensaver:</b> The "SCREENSAVER" menu is displayed. <b>ECO menu:</b> The "ECO MODE SETTINGS" menu is displayed. <b>Set up TIMER:</b> The "SET UP TIMER" menu is displayed. <b>Note:</b> Factory settings are as follows. FUNCTION1 button: Signal FUNCTION2 button: Screensaver <b>Use the FUNCTION button</b> The menu screen is displayed. (Example: Signal)  Press the FUNCTION button to exit from the menu.
<b>Power Switch Lock</b>	Sets the lock setting for the display Power switch. <b>On:</b> Power switch operation is disabled. <b>Off:</b> Power switch operation is enabled.

### Normalization

When both main unit buttons and remote control are disabled due to the "Button lock", "Remocon User level" or "Remote ID" adjustments, set all the values "Off" so that all the buttons are enabled again.

Press the  - /  button on main unit together with  button on the remote control and hold for more than 5 seconds. The "Shipping" menu is displayed and the lock is released when it disappears.

## Input Search

When a signal is not detected, another input with a signal is automatically selected.

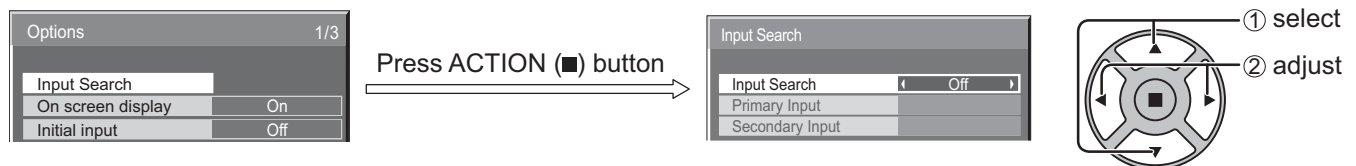

### Input Search

**Off:** When there is no signal, the input is not switched automatically.

**All Inputs:** Searches all inputs and switches to an input with a signal.

**Priority:** Searches "Primary Input" and "Secondary Input" in order and switches to an input with a signal.



"SEARCHING..." is displayed during the input search.

### Primary Input, Secondary Input

Set the input to search when "Priority" is selected.

**(NONE) <=> SLOT INPUT\* <=> VIDEO <=> Component/RGB <=> PC <=> DVI <=> HDMI**

\* "SLOT INPUT" is displayed when an optional Terminal Board is installed.

When a Terminal Board with dual input terminals is installed, "SLOT INPUT A" and "SLOT INPUT B" are displayed.

### Note:

- This menu is available only when "Input lock" is "Off". (see page 46)



# Using Network Function

This unit has a network function to control the network connected display with your computer.

**Note:**

To use the network function, set each “NETWORK SETUP” setting and make sure to set the “CONTROL I/F SELECT” to “LAN”. (see page 45)

When “LAN” is set, power indicator lights orange under the condition of power off with remote control (stand-by state).

---

## Example of Network Connection

---

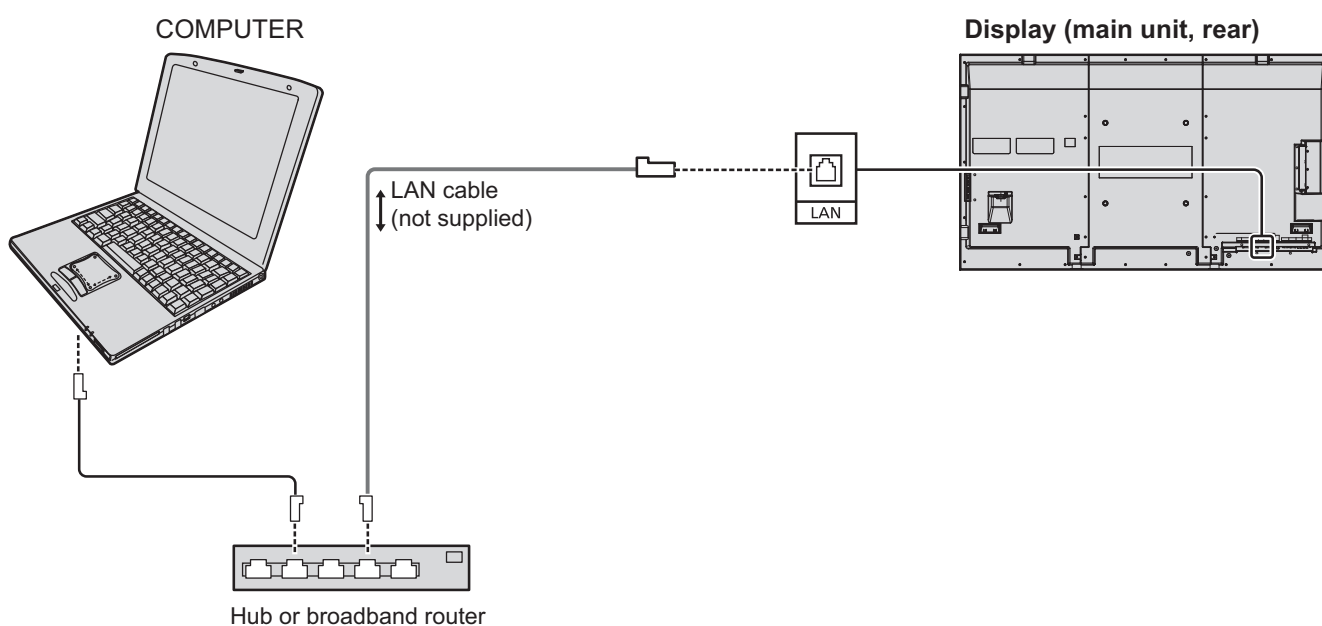

**Notes:**

- Make sure the broadband router or hub supports 10BASE-T/100BASE-TX.
- To connect a device using 100BASE-TX, use “category 5” LAN cable.
- Touching the LAN terminal with a statically charged hand (body) may cause damage due to its discharge. Do not touch the LAN terminal or a metal part of the LAN cable.
- For instructions on how to connect, consult your network administrator.

---

## Command Control

---

Network function of the unit can control the unit in the same way as serial control from a network.

**Supported commands**

Commands used in the serial control are supported. (see page 16)

**Note:**

Consult your local Panasonic dealer for detail instructions on command usage.

## Using Network Function

# PJLink™ Protocol

The network function of the unit conforms with PJLink™ class 1 and you can operate the following actions from your computer using PJLink™ protocol.

- Display setup
- Display status query

### Supported commands

Commands to control the unit with PJLink™ protocol are shown in the table below.

Command	Control	Remark
POWR	Power control	Parameter 0 = Standby 1 = Power "On"
POWR ?	Power status query	Parameter 0 = Standby 1 = Power "On"
INPT	Input switch	Parameter
INPT ?	Input switch query	See the parameter for command INST ?
AVMT	Shutter control	Parameter 10 = Picture On (picture mute deactivated), 11 = Picture Off (picture on mute) 20 = Audio On (audio mute deactivated), 21 = Audio Off (audio on mute) 30 = Shutter mode Off (picture and audio mute deactivated) 31 = Shutter mode On (picture and audio on mute)
AVMT ?	Shutter control query	Parameter 11 = Picture Off (picture on mute) 21 = Audio Off (audio on mute) 30 = Shutter mode Off (picture and audio mute deactivated) 31 = Shutter mode On (picture and audio on mute)
ERST ?	Error status query	Parameter First byte: Means fan error. 0 or 2. Second byte: 0 Third byte: 0 Fourth byte: 0 Fifth byte: 0 Sixth byte: Means other error. 0 or 2. Meaning of the 0 – 2 settings: 0 = Error is not detected, 2 = Error
LAMP ?	Lamp status query	Not supported
INST ?	Input switch list query	Parameter Numbers 11 to 13 are depending on the slot installation condition 11: PC IN input (PC) When a single input terminal board is attached 11: SLOT input (SLOT INPUT) 12: PC IN input (PC) When a dual input terminal board is attached 11: SLOT input (SLOT INPUT A) 12: SLOT input (SLOT INPUT B) 13: PC IN input (PC) 21: VIDEO input (VIDEO) 31: HDMI input (HDMI) 22: COMPONENT/RGB IN input (COMPONENT) 32: DVI-D IN input (DVI)
NAME ?	Projector name query	Returns empty character (no name information)
INF1 ?	Manufacturer name query	Returns "Panasonic"
INF2 ?	Model name query	Returns "TH-70/80LF50"
INFO ?	Other information query	Returns version number
CLSS ?	Class information query	Returns "1"

### PJLink™ security authentication

Set "Panasonic" for the PJLink™ password.

- PJLink™ is a pending trademark in Japan, the United States, and other countries or areas.

# Using Web Browser Control

You can use a Web browser to control the unit and set up a network and password.

## Before Using Web Browser Control

To use the Web browser control, the unit and computer setups are required.

### Unit Setup

Set each "NETWORK SETUP" setting and make sure to set the "CONTROL I/F SELECT" to "LAN". (see page 45)

### Computer Setup

Disable the proxy server settings and enable JavaScript.

#### (Windows)

##### Disable proxy server settings

- 1 Display [Internet Properties] window.  
Click [Start] – [Control Panel] – [Network and Internet Connections] – [Internet Options].
- 2 Click the [Connections] tab and then [LAN Settings].
- 3 Deselect the [Use automatic configuration script] and [Use a proxy server for your LAN] boxes.
- 4 Click [OK].

##### Enable JavaScript

- 1 Display [Internet Properties] window.  
Click [Start] – [Control Panel] – [Network and Internet Connections] – [Internet Options].
- 2 Set the security level on the [Security] tab to [Default Level]. Alternatively enable [Active scripting] from the [Custom Level] button.

#### (Macintosh)

##### Disable proxy server settings

- 1 From the [Safari] menu, click [Preferences].  
General screen is displayed.
- 2 From the [Advanced] tab, click the [Change Settings...] button next to [Proxies]. Click [Proxies] and set up a proxy server.
- 3 Deselect the [Web Proxy] and [Automatic Proxy Configuration] boxes.
- 4 Click [Apply Now].

##### Enable JavaScript

- 1 Display [Security] of Safari.
- 2 Select [Enable JavaScript] under [Web content].

## Access from Web Browser

Access to the TOP screen of the Web browser control using a Web browser.

- 1 Start your Web browser.
- 2 Enter the IP address set with the "NETWORK SETUP" of the unit. (see page 45)

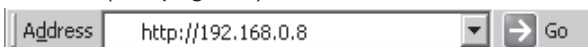

- 3 Enter the user name and password when the Authentication screen is displayed.

### Authentication screen

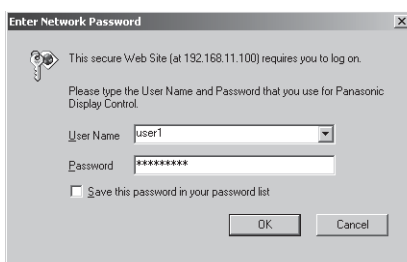

- 4 Click [OK].  
After logged in, the TOP screen of the Web browser control is displayed. (see page 52)

### Notes:

- The password used here is the same password used for command control and the PJLink™ security authentication.
- Default user name and password are as follows:  
User name: user1  
Password: Panasonic
- The password can be changed on the Password Setup screen after logging in (see page 53). The user name cannot be changed.
- Under no circumstances, Panasonic Corporation or its associated companies will ask customers their password directly.  
Even if you are asked directly, please do not reveal your password.

# Using Web Browser Control

## TOP screen structure of the Web browser control

After logging in, the TOP screen of the Web browser control is displayed.

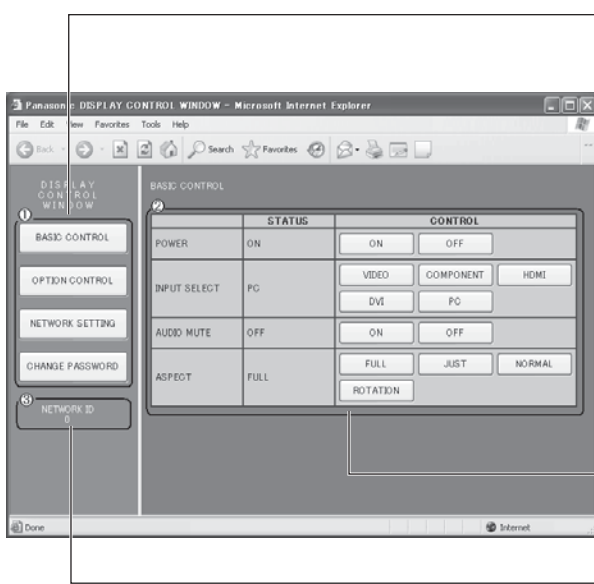

① **Menu**

Menu items are displayed. When a button is clicked, setup screen of each item is displayed.

Item	Details
BASIC CONTROL	BASIC CONTROL screen is displayed. (see below)
OPTION CONTROL	OPTION CONTROL screen is displayed. (see below)
NETWORK SETTING	Network Setup screen is displayed. (see page 53)
CHANGE PASSWORD	Password setup screen is displayed. (see page 53)

② According to the selected item from the menu, setup status or set items are displayed.

③ **Network ID information**

ID to identify the unit is displayed.

# Display Control (BASIC CONTROL/OPTION CONTROL Screen)

Click BASIC CONTROL or OPTION CONTROL from the menu. Various controls of the unit can be set.

### BASIC CONTROL screen

Click BASIC CONTROL from the menu. Unit status and buttons to change settings are displayed.

	STATUS	CONTROL
POWER	ON	ON OFF
INPUT SELECT	PC	VIDEO COMPONENT HDMI DVI PC
AUDIO MUTE	OFF	ON OFF
ASPECT	FULL	FULL JUST NORMAL ROTATION

Item	Details
POWER	Switch ON/OFF of the unit power.
INPUT SELECT	Switch the input signals. Displayed buttons vary according to the connection status of the video device.
AUDIO MUTE	Switch ON/OFF of the sound mute.
ASPECT	Switch the screen modes

### OPTION CONTROL screen

Click OPTION CONTROL from the menu. Command input field for command control of the unit is displayed.

COMMAND	<input type="text"/>
RESPONSE	<input type="text"/>
SEND	

Item	Details
COMMAND	Enter a command. Use the same command used for the serial control. (see page 16)
RESPONSE	Response from the unit is displayed.
SEND	Command is sent and run.

**Note:**

After the settings are changed, it may take a while till the display's response is displayed.

# NETWORK SETTING (Network Setup Screen)

Click NETWORK SETTING from the menu. Various settings of a network can be set. For the details of the setting items, please check NETWORK SETUP under the SET UP of the unit. (see page 45)

DHCP	<input type="radio"/> OFF <input type="radio"/> ON
IP ADDRESS	<input type="text" value="192.168.0.8"/>
SUBNET MASK	<input type="text" value="255.255.255.0"/>
GATEWAY	<input type="text" value="192.168.0.1"/>
PORT	<input type="text" value="1024"/>
LAN SPEED	<input type="radio"/> AUTO <input type="radio"/> 10 HALF <input type="radio"/> 10 FULL <input type="radio"/> 100 HALF <input type="radio"/> 100 FULL
NETWORK ID	<input type="text" value="0"/>
<input type="button" value="SAVE"/>	

**Notes:**

- To use a DHCP server, make sure the DHCP server is started.
- During a DHCP server is used, IP ADDRESS, SUBNET MASK, and GATEWAY values cannot be entered.
- When the set values are changed properly, “NETWORK SETTING CHANGED.” message and the changed set items are displayed.

Item	Details
DHCP	Set to ON when a DHCP server is used, or OFF when it is not used.
IP ADDRESS	Enter an IP address.
SUBNET MASK	Enter a subnet mask.
GATEWAY	Enter a gateway address.
PORT	Enter the port number used for command control. The available setting range is 1024 - 65535.
LAN SPEED	Set the connection speed of the LAN environment.
NETWORK ID	Set the ID to identify this unit. The available setting range is 0 - 99.
SAVE	Save the each set value.

# Password Setting (Password Setup Screen)

Click CHANGE PASSWORD from the menu. Password to access the Web browser control can be set. When the password is changed in this screen, the password used for command control and the PJLink™ security authentication is also changed.

OLD PASSWORD	<input type="password" value="....."/>
NEW PASSWORD	<input type="password" value="....."/>
NEW PASSWORD (RETYPE)	<input type="password" value="....."/>
<input type="button" value="SAVE"/>	











**Notes:**

- The default password is “Panasonic”.
- Up to 32 alphanumeric characters can be used for a password.
- When the password is changed properly, “Password has changed.” message is displayed.

Item	Details
OLD PASSWORD	Enter the old password.
NEW PASSWORD	Enter the new password.
NEW PASSWORD (RETYPE)	Enter the password entered in “NEW PASSWORD” for confirmation.
SAVE	Save the new password. The confirmation screen is displayed. Click OK to change the password.

# Troubleshooting

**Before you call for service, determine the symptoms and make a few simple checks as shown below.**

Symptoms		Checks
Picture	Sound	
 Interference	 Noisy Sound	Electrical Appliances Cars / Motorcycles Fluorescent light
 Normal Picture	 No Sound	Volume (Check whether the mute function has been activated on the remote control.)
 No Picture	 No Sound	Not plugged into AC outlet Not switched on PICTURE and BRIGHTNESS/Volume setting (Check by pressing the power switch or stand-by button on the remote control.)
 No Picture	 Normal Sound	If a signal with a non-applicable color system format, or frequency is input, only the input terminal indication is displayed.
 No Color	 Normal Sound	Color controls set at minimum level. (see page 27, 28) COLOR SYSTEM (see page 42)
No remote control operations can be performed.		Check whether the batteries have discharged completely and, if they have not, whether they were inserted properly. Check whether the remote control sensor is exposed to an outdoor light or a strong fluorescent light. Check whether the remote control designed specifically for use with the unit is being used. (The unit cannot be operated by any other remote control.)
A cracking sound is sometimes heard from the unit.		If there is nothing wrong with the picture or sound, this is the sound of the cabinet undergoing very slight contractions in response to changes in the room temperature. There are no adverse effects on the performance or other aspects.
The top or bottom of the picture on the screen is cut off when I use the zoom function.		Adjust the position of the picture on the screen.
Areas at the top and bottom of the screen where the image is missing appear when I use the zoom function.		When using a video software program (such as a cinema size program) with a screen wider than one in the 16:9 mode, blank areas separate from the images are formed at the top and bottom of the screen.
I can hear sounds coming from inside the unit.		When the power is turned on, a sound of the display panel being driven may be heard: This is normal and not indicative of malfunctioning.
Parts of the unit become hot.		Even when the temperature of parts of the front, top and rear panels has risen, these temperature rises will not pose any problems in terms of performance or quality.
Power automatically turns off unexpectedly.		Check the settings of "NO SIGNAL POWER OFF", "PC POWER MANAGEMENT", "DVI-D POWER MANAGEMENT" and "NO ACTIVITY POWER OFF". Any of them may be set to "ON (ENABLE)". (see page 34, 35)
There is no picture displayed or sound output sometimes.		When HDMI or DVI signals are input to the Display using a selector or distributor, sound or images may not be output in the normal fashion depending on the selector or distributor used. The symptoms may be improved by turning the power off and on again, or by replacing the selector or distributor.
This LCD Display uses special image processing. Hence a slight time lag may occur between image and audio, depending on the type of input signal. However, this is not a malfunction.		

## LCD Display panel

Symptoms	Check
The screen darkens slightly when bright pictures with minimal movements are shown.	The screen will darken slightly when photos, still images of a computer or other pictures with minimal movements are shown for an extended period. This is done to reduce image retention on the screen and the shortening of the screen's service life: It is normal and not indicative of malfunctioning.
It takes a while for the picture to appear.	The unit digitally processes the various signals in order to reproduce esthetically pleasing images. As such, it sometimes takes a few moments for the picture to appear when the power has been turned on, when the input has been switched.
The edges of the images flicker.	Due to the characteristics of the system used to drive the panel, the edges may appear to flicker in the fast-moving parts of the images: This is normal and not indicative of malfunctioning.
There may be red spots, blue spots, green spots and black spots on the screen.	This is a characteristic of liquid crystal panels and is not a problem. The liquid crystal panel is built with very high precision technology giving you fine picture details. Occasionally, a few non-active pixels may appear on the screen as fixed points of red, blue, green, or black. Please note this does not affect the performance of your LCD.
 <p>Image retention appears</p>	Image retention may occur. If you display a still picture for an extended period, the image might remain on the screen. However, it will disappear after a while. This is not considered as malfunction.

# Applicable input signals

## PC signals

\*Mark: Applicable input signal

	Signal name	Horizontal frequency (kHz)	Vertical frequency (Hz)	RGB IN (Dot clock(MHz))	PC IN (Dot clock (MHz))	DVI-D IN (Dot clock (MHz))	HDMI
1	640x400@70Hz	31.46	70.07	*(25.17)	*(25.17)		
2	640x480@60Hz	31.47	59.94	*(25.18)	*(25.18)	*(25.18)	*
3	640x480@72Hz	37.86	72.81	*(31.5)	*(31.5)		
4	640x480@75Hz	37.50	75.00	*(31.5)	*(31.5)		
5	640x480@85Hz	43.27	85.01	*(36.0)	*(36.0)		
6	800x600@56Hz	35.16	56.25	*(36.0)	*(36.0)		
7	800x600@60Hz	37.88	60.32	*(40.0)	*(40.0)	*(40.0)	*
8	800x600@72Hz	48.08	72.19	*(50.0)	*(50.0)		
9	800x600@75Hz	46.88	75.00	*(49.5)	*(49.5)		
10	800x600@85Hz	53.67	85.06	*(56.25)	*(56.25)		
11	852x480@60Hz	31.47	59.94			*(33.24)	*
12	1024x768@50Hz	39.55	50.00			*(51.89)	*
13	1024x768@60Hz	48.36	60.00	*(65.0)	*(65.0)	*(65.0)	*
14	1024x768@70Hz	56.48	70.07	*(75.0)	*(75.0)		
15	1024x768@75Hz	60.02	75.03	*(78.75)	*(78.75)		
16	1024x768@85Hz	68.68	85.00	*(94.5)	*(94.5)		
17	1066x600@60Hz	37.64	59.94			*(53.0)	*
18	1152x864@60Hz	53.70	60.00			*(81.62)	*
19	1152x864@75Hz	67.50	75.00	*(108.0)	*(108.0)		
20	1280x768@60Hz	47.70	60.00	*(80.14)	*(80.14)		
21	1280x960@60Hz	60.00	60.00	*(108.0)	*(108.0)		
22	1280x960@85Hz	85.94	85.00	*(148.5)	*(148.5)		
23	1280x1024@60Hz	63.98	60.02	*(108.0)	*(108.0)	*(108.0)	*
24	1280x1024@75Hz	79.98	75.02	*(135.0)	*(135.0)		
25	1280x1024@85Hz	91.15	85.02		*(157.5) *1		
26	1366x768@50Hz	39.55	50.00			*(69.92)	*
27	1366x768@60Hz	48.36	60.00	*(86.71)	*(86.71)	*(87.44)	*
28	1400x1050@60Hz	65.22	60.00			*(122.61)	*
29	1600x1200@60Hz	75.00	60.00	*(162.0)	*(162.0)	*(162.0)	*
30	1920x1080@60Hz	67.50	60.00	*(148.5)	*(148.5)	*(148.5)	*
31	1920x1200@60Hz	74.04	59.95			*(154.0)	*
32	Macintosh13"(640x480)	35.00	66.67	*(30.24)	*(30.24)		
33	Macintosh16"(832x624)	49.72	74.55	*(57.28)	*(57.28)		
34	Macintosh21"(1152x870)	68.68	75.06	*(100.0)	*(100.0)		

\*1 Not compatible with SYNC ON G.

• The signal format automatically detected may differ from the actual input signal in display.

## Applicable input signals

### Component signals

\*Mark: Applicable input signal

	Signal name	Horizontal frequency (kHz)	Vertical frequency (Hz)	COMPONENT IN (Dot clock (MHz))	DVI-D IN (Dot clock (MHz))	HDMI
1	525(480)/60i	15.73	59.94	* (13.5)	* (27.0)	*
2	525(480)/60p	31.47	59.94	* (27.0)	* (27.0)	*
3	625(575)/50i	15.63	50.00	* (13.5)		
4	625(576)/50i	15.63	50.00		* (27.0)	*
5	625(575)/50p	31.25	50.00	* (27.0)		*
6	625(576)/50p	31.25	50.00		* (27.0)	*
7	750(720)/60p	45.00	60.00	* (74.25)	* (74.25)	*
8	750(720)/50p	37.50	50.00	* (74.25)	* (74.25)	*
9	1,125(1,080)/60p	67.50	60.00	* (148.5)*1	* (148.5)	*
10	1,125(1,080)/60i	33.75	60.00	* (74.25)*1	* (74.25)	*
11	1,125(1,080)/50p	56.25	50.00	* (148.5)*1	* (148.5)	*
12	1,125(1,080)/50i	28.13	50.00	* (74.25)*1	* (74.25)	*
13	1,125(1,080)/24sF	27.00	48.00	* (74.25)*2		
14	1,125(1,080)/30p	33.75	30.00	* (74.25)*1	* (74.25)	*
15	1,125(1,080)/25p	28.13	25.00	* (74.25)*1	* (74.25)	*
16	1,125(1,080)/24p	27.00	24.00	* (74.25)*1	* (74.25)	*

\*1: Based on SMPTE 274M standard.

\*2: Based on SMPTE RP211 standard.

### Video signals (VIDEO)

	Signal name	Horizontal frequency (kHz)	Vertical frequency (Hz)
1	NTSC	15.73	59.94
2	PAL	15.63	50.00
3	PAL60	15.73	59.94
4	SECAM	15.63	50.00
5	NTSC 4.43	15.73	59.94
6	PAL N	15.63	50.00
7	PAL M	15.73	59.94



# Shipping condition

This function allows you to reset the unit to the factory setting.

**1**  Press to display the SET UP menu.

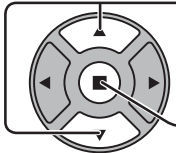
**2**  Press to select "OSD LANGUAGE".  
Press for more than 3 seconds.

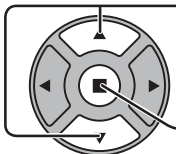
**3**  Press to select "Shipping".  
Press to display the Shipping menu.

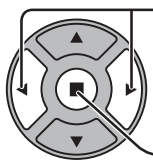
**4**  Press to select "YES".  
Press to confirm.

**5** Wait for 10 seconds.

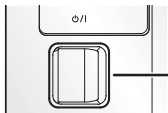
**6**  Press the power switch (⏻/⏻) on main unit to turn the power off.  
\* If the power switch is locked, please disconnect the AC cord plug from the wall outlet.

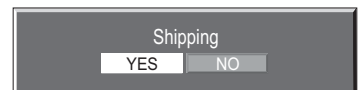
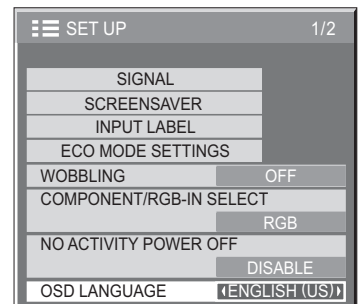

[from the unit]

- 1 Press the MENU button till the SET UP menu is displayed.
- 2 Press the Volume Up "+" or Down "-" button to select "OSD LANGUAGE".
- 3 Press and hold the ENTER button till the Shipping menu is displayed.
- 4 Press the Volume Up "+" or Down "-" button to select "YES".
- 5 Press the ENTER button and wait for 10 sec.
- 6 Press the power switch (⏻/⏻) on main unit to turn the power off.  
\* If the power switch is locked, please disconnect the AC cord plug from the wall outlet.

# Specifications

	TH-70LF50U	TH-80LF50U
<b>Power Source</b>	110 - 127 V AC, 50/60 Hz	
<b>Power Consumption</b>		
Rated Power Consumption	260 W	380 W
Stand-by condition	0.5 W	0.5 W
Power off condition	0.3 W	0.3 W
<b>LCD Display panel</b>	70-inch VA panel (LED backlight), 16:9 aspect ratio	80-inch VA panel (LED backlight), 16:9 aspect ratio
<b>Screen size</b>	60.5" (1,538 mm) (W) × 34.0" (865 mm) (H) × 69.4" (1,765 mm) (diagonal)	69.7" (1,771 mm) (W) × 39.2" (996 mm) (H) × 80.0" (2,032 mm) (diagonal)
(No. of pixels)	2,073,600 (1,920 (W) × 1,080 (H)) [5,760 × 1,080 dots]	2,073,600 (1,920 (W) × 1,080 (H)) [5,760 × 1,080 dots]
<b>Operating condition</b>		
Temperature	32 °F - 104 °F (0 °C - 40 °C)	32 °F - 104 °F (0 °C - 40 °C)
Humidity	20 % - 80 %	20 % - 80 %
<b>Applicable signals</b>		
Color System	NTSC, PAL, PAL60, SECAM, NTSC 4.43, PAL M, PAL N	
Scanning format	525 (480) / 60i · 60p, 625 (575) / 50i · 50p, 750 (720) / 60p · 50p, 1125 (1080) / 60i · 60p · 50i · 50p · 24p · 25p · 30p · 24sF	
PC signals	VGA, SVGA, XGA, SXGA UXGA .... (compressed) Horizontal scanning frequency 30 - 110 kHz Vertical scanning frequency 48 - 120 Hz	
<b>Connection terminals</b>		
LAN	RJ45 10BASE-T/100BASE-TX, compatible with PLink™	
VIDEO	BNC	1.0 Vp-p (75 Ω)
AUDIO L-R	RCA Pin jack × 2	0.5 Vrms
HDMI	TYPE A Connector	
<b>COMPONENT/RGB IN</b>		
G/Y	BNC	with sync 1.0 Vp-p (75 Ω)
B/Pb/Cb	BNC	0.7 Vp-p (75 Ω)
R/Pr/CR	BNC	0.7 Vp-p (75 Ω)
AUDIO L-R	RCA Pin jack × 2	0.5 Vrms
DVI-D IN DVI-D OUT	DVI-D 24 Pin × 2 Content Protection	Compliance with DVI Revision 1.0 Compatible with HDCP 1.1
AUDIO	Stereo mini jack (M3) × 1	0.5 Vrms, Shared with PC IN
PC IN	High-Density Mini D-sub 15 Pin	G with sync 1.0 Vp-p (75 Ω) G without sync 0.7 Vp-p (75 Ω) B: 0.7 Vp-p (75 Ω) R: 0.7 Vp-p (75 Ω) HD/VD: 1.0 - 5.0 Vp-p (high impedance) 0.5 Vrms, Shared with DVI-D IN
AUDIO	Stereo mini jack (M3) × 1	
SERIAL IN SERIAL OUT	External Control Terminal D-sub 9 Pin × 2	RS-232C compatible
AUDIO OUT	RCA PIN JACK × 2 (L / R) Output level: Variable (-∞ — 0 dB)	[INPUT 1 kHz / 0 dB, 10 kΩ Load]
<b>Dimensions (W × H × D)</b>	63.2" (1,604 mm) × 36.7" (931 mm) × 3.5" (89 mm)	72.8" (1,848 mm) × 42.3" (1,073 mm) × 3.5" (89 mm)
<b>Mass (weight)</b>	approx. 103.7 lbs	approx. 132.3 lbs

**Note:**

Design and specifications are subject to change without notice. Mass and dimensions shown are approximate.

## <Software Information for This Product>

This product has software installed partially licensed under the Free BSD LICENSE.

Free BSD LICENSE regulations under the above specifications are as follows:

(These regulations are set by the third party; therefore the original (English) regulations are stated.)

Copyright © 1980, 1986, 1993

The Regents of the University of California. All rights reserved.

Redistribution and use in source and binary forms, with or without modification, are permitted provided that the following conditions are met:

1. Redistributions of source code must retain the above copyright notice, this list of conditions and the following disclaimer.
2. Redistributions in binary form must reproduce the above copyright notice, this list of conditions and the following disclaimer in the documentation and/or other materials provided with the distribution.
3. All advertising materials mentioning features or use of this software must display the following acknowledgement:  
This product includes software developed by the University of California, Berkeley and its contributors.
4. Neither the name of the University nor the names of its contributors may be used to endorse or promote products derived from this software without specific prior written permission.

THIS SOFTWARE IS PROVIDED BY THE REGENTS AND CONTRIBUTORS "AS IS" AND ANY EXPRESS OR IMPLIED WARRANTIES, INCLUDING, BUT NOT LIMITED TO, THE IMPLIED WARRANTIES OF MERCHANTABILITY AND FITNESS FOR A PARTICULAR PURPOSE ARE DISCLAIMED. IN NO EVENT SHALL THE REGENTS OR CONTRIBUTORS BE LIABLE FOR ANY DIRECT, INDIRECT, INCIDENTAL, SPECIAL, EXEMPLARY, OR CONSEQUENTIAL DAMAGES (INCLUDING, BUT NOT LIMITED TO, PROCUREMENT OF SUBSTITUTE GOODS OR SERVICES; LOSS OF USE, DATA, OR PROFITS; OR BUSINESS INTERRUPTION) HOWEVER CAUSED AND ON ANY THEORY OF LIABILITY, WHETHER IN CONTRACT, STRICT LIABILITY, OR TORT (INCLUDING NEGLIGENCE OR OTHERWISE) ARISING IN ANY WAY OUT OF THE USE OF THIS SOFTWARE, EVEN IF ADVISED OF THE POSSIBILITY OF SUCH DAMAGE.

USA only: Disposal may be regulated in your community due to environmental considerations. For disposal or recycling information, please visit Panasonic website: <http://www.panasonic.com/environmental> or call 1-888-769-0149.

**Customer's Record**

The model number and serial number of this product can be found on its back cover. You should note this serial number in the space provided below and retain this book, plus your purchase receipt, as a permanent record of your purchase to aid in identification in the event of theft or loss, and for Warranty Service purposes.

Model Number \_\_\_\_\_

Serial Number \_\_\_\_\_

© Panasonic Corporation 2012

---

**Panasonic System Communications Company of North America**  
Unit of Panasonic Corporation of North America

**Executive Office :**  
Three Panasonic Way 2F-5, Secaucus, NJ 07094

**Panasonic Canada Inc.**  
5770 Ambler Drive  
Mississauga, Ontario  
L4W 2T3