

SYM	DATE	REVISION	SIGNED	CHECKED
△				
△				
△				

Sym	Parts Name	Qty	Material & Size	Process/Remark
1	Cover (R)	1	ABS/PC Resin	Coating (Fine Silver)
2	Dome Lens Cover	1	ABS/PC Resin	Coating (Fine Silver)
3	Dome Lens	1	Acrylic Resin	
4	Cover (L)	1	ABS/PC Resin	Coating (Fine Silver)
5	Side Panel	2	ABS/PC Resin	Coating (Fine Silver)
6	Base Case	1	ABS/PC Resin	Coating (Fine Silver) Printing
7	SD Card Cover	1	ABS/PC Resin	Coating (Fine Silver) Printing
8	Panasonic Plate	1	ABS/PC Resin	Coating (Fine Silver) Printing
9	Safety-Wire Hook	1	Carbon Steel/Stainless Steel	
10	Lock Plate	1	Aluminium Alloy	
11	Rubber Foot	4	Polyurethane foam	
12	Camera Mount Plate	1	Carbon Steel	Plating
13	Name Plate	1	Polyester film	Printing
14	Code Label(MAC Address)	1	Polyester film	Printing
15	SD Card Socket	1		
16	Production date Label	1	Polyester film	Printing
17	Status Indication Lamp	1		
18	Serial No. Label	1	Polyester film	Printing
19	AUX Label	1	Polyester film	Printing
20	LINK LED	1		
21	RJ-45 Terminal	1		
22	ACT LED	1		
23	INITIAL SET Switch	1		
24	POWER Connector	1		
25	EXT I/O Terminal	1		
26	MIC IN Connector	1		
27	AUDIO OUT Connector	1		
28	MONITOR OUT Connector	1		
29	Base Mount Plate	1	Carbon Steel/Stainless Steel	
30	Decoration Cover	1	ABS/PC Resin	Coating (Fine Silver) Printing
31	Safety-wire	1	Stainless Steel	
32	Camera Fixing Screw	1	Carbon Steel M3	Plating

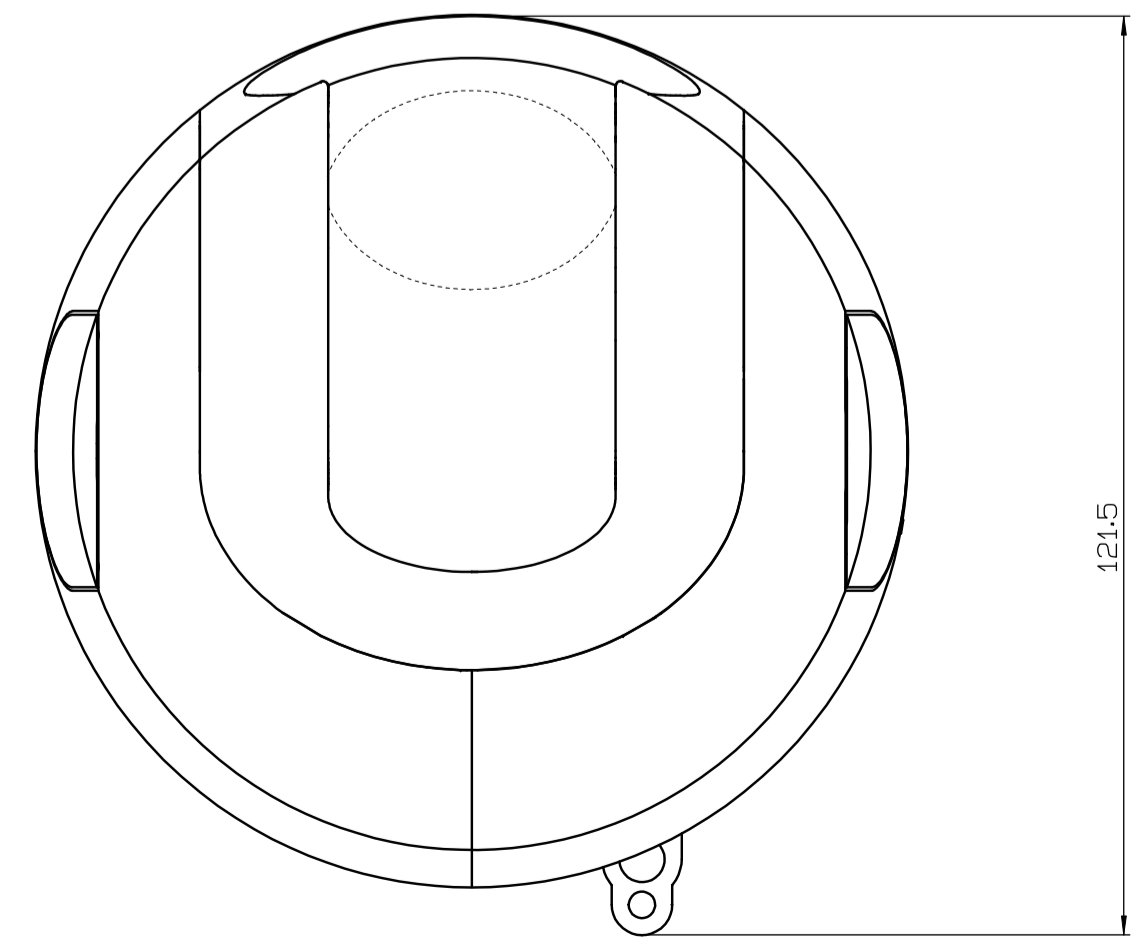
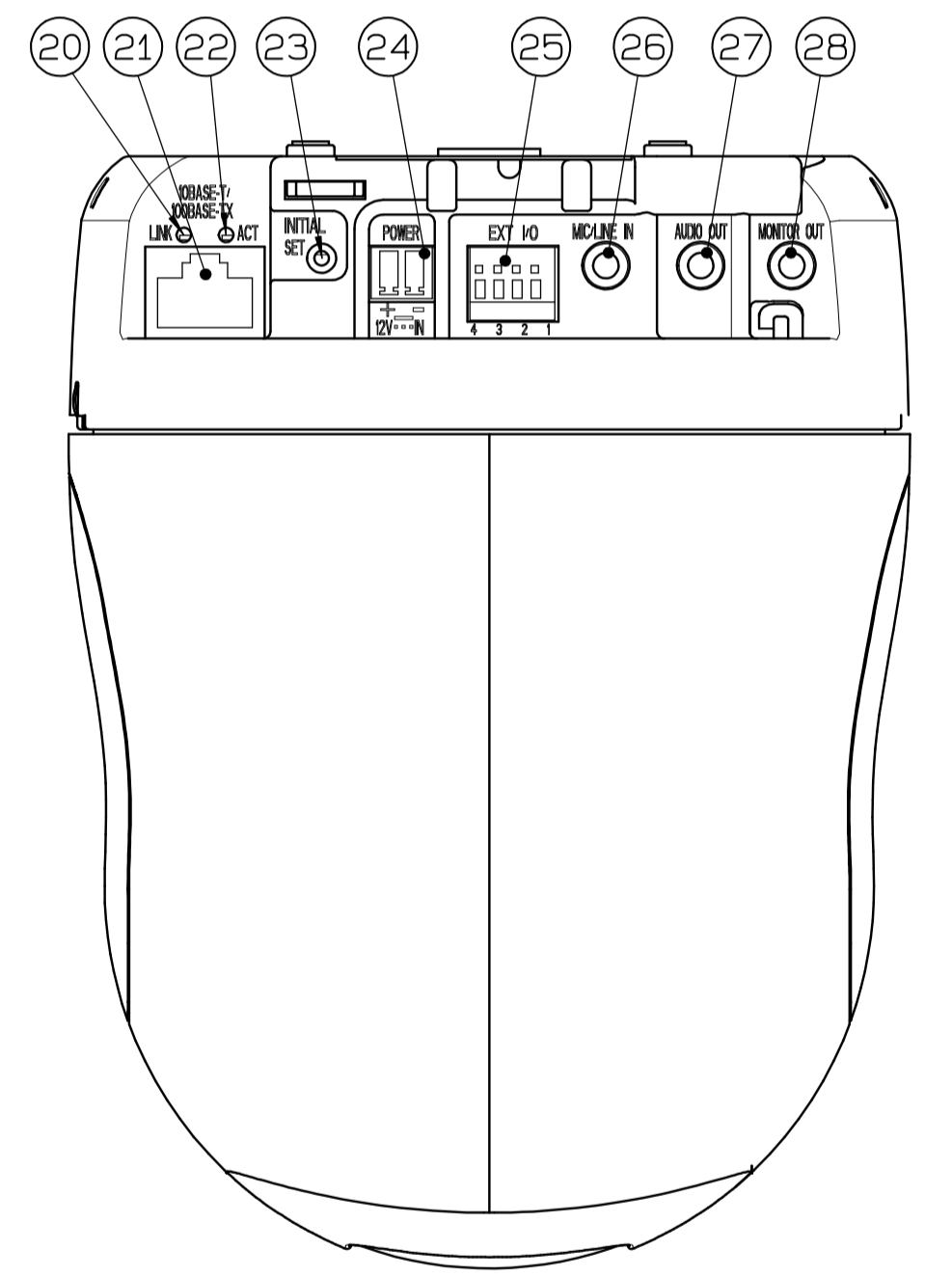
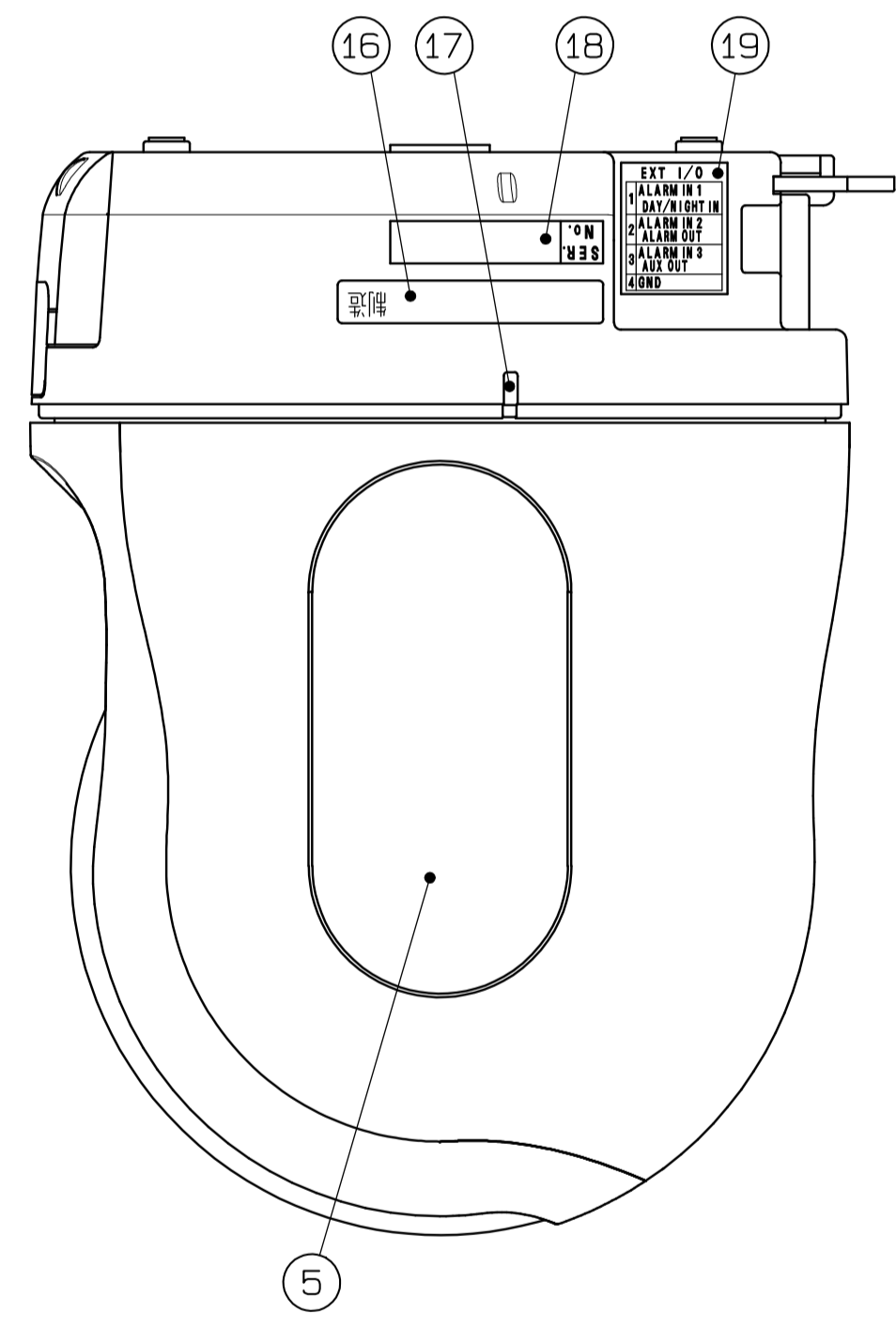
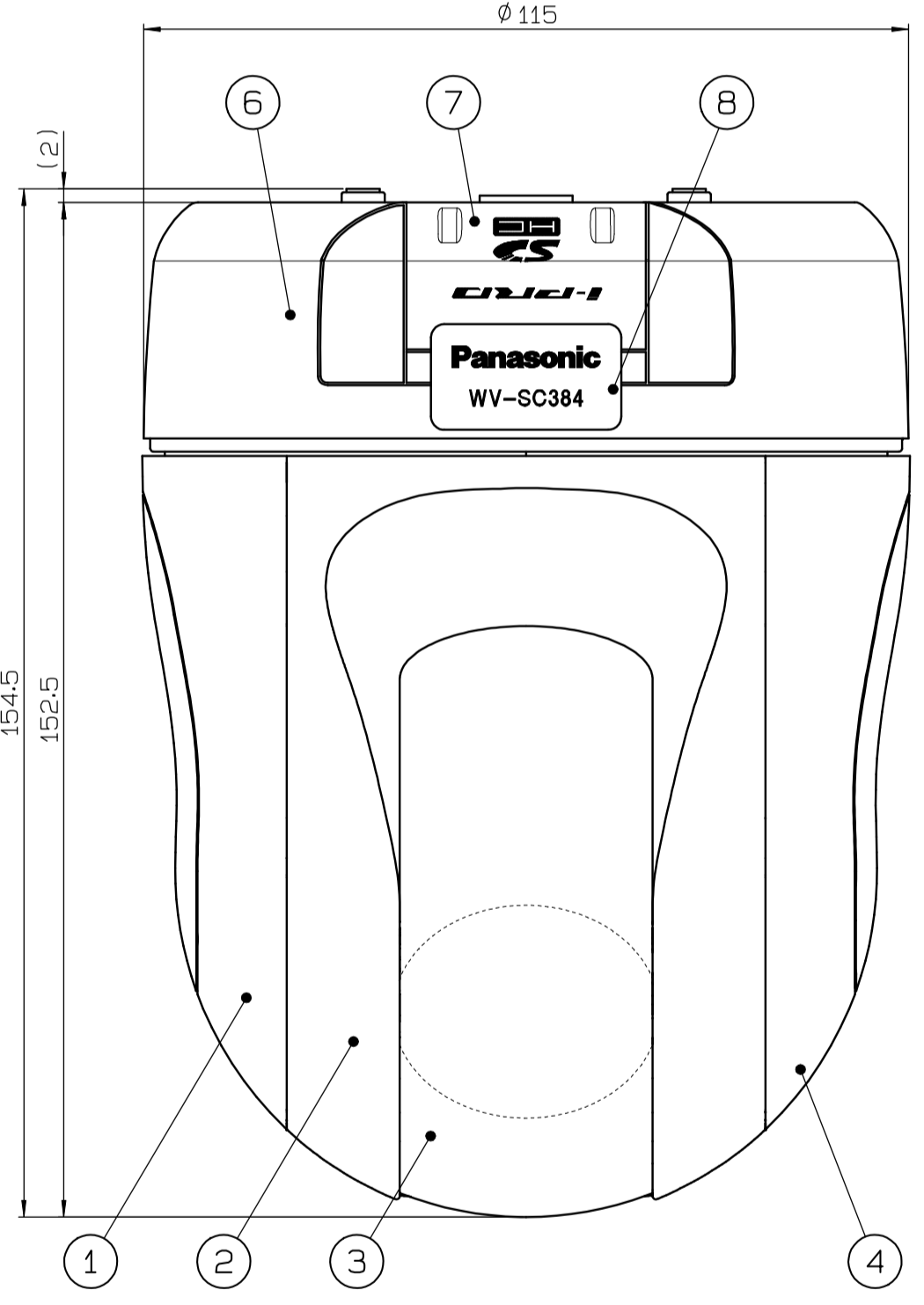
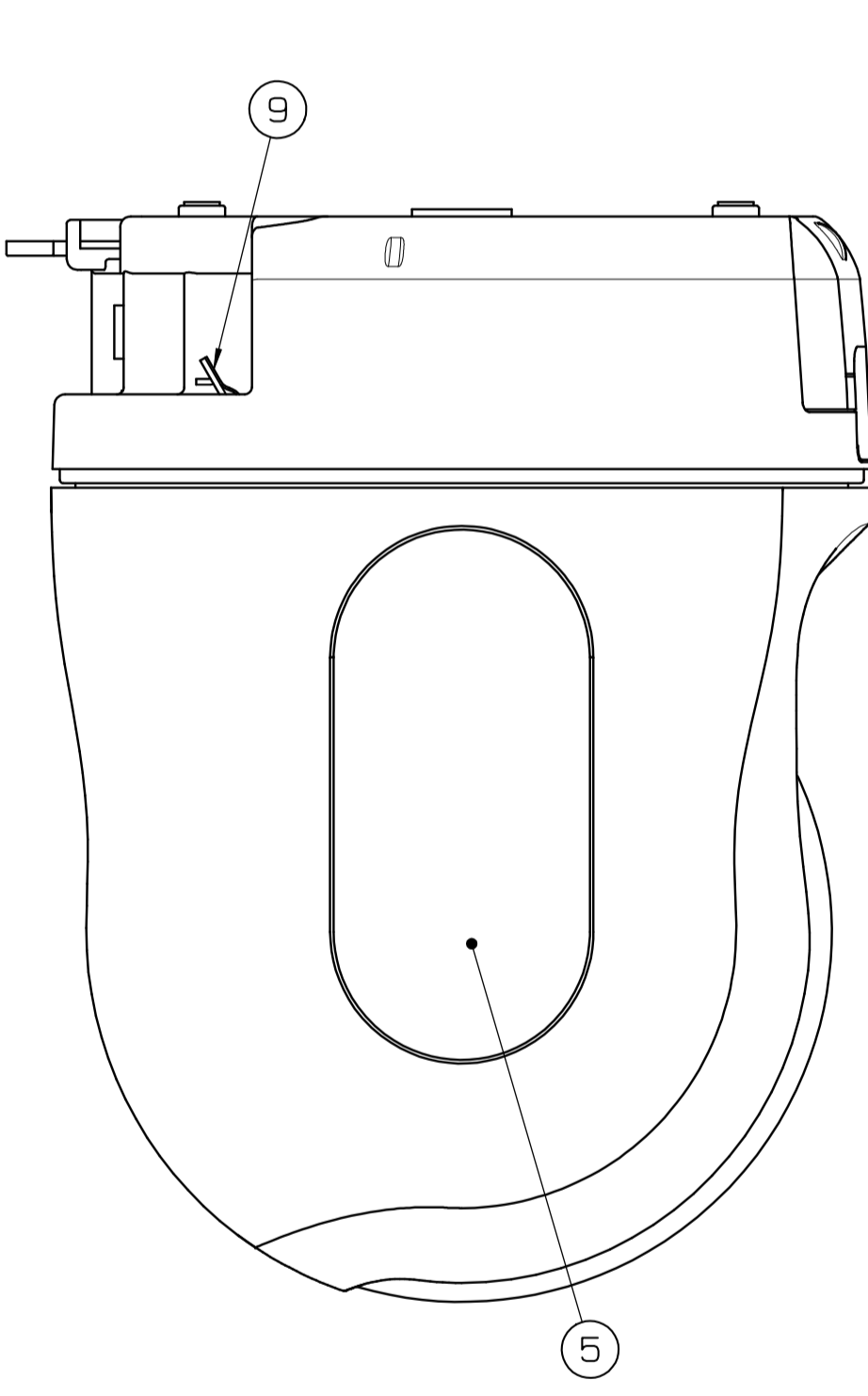
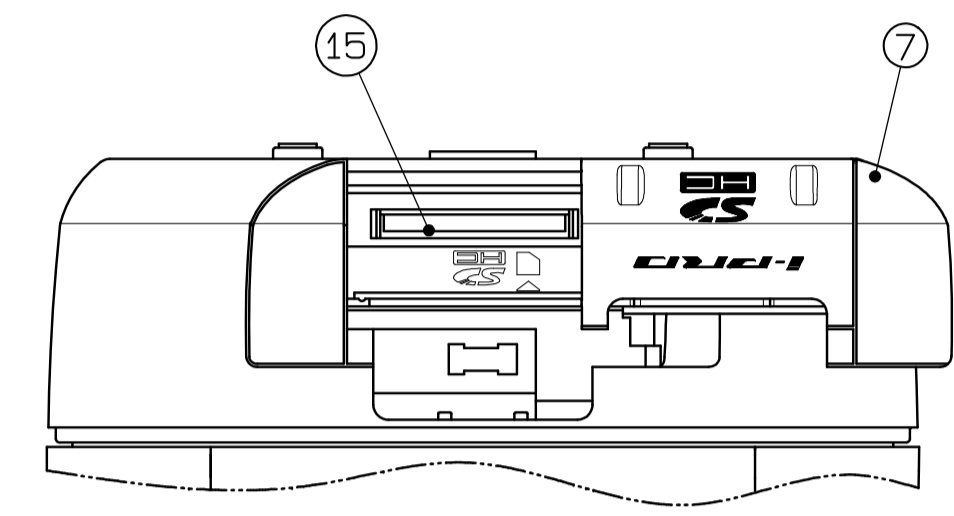
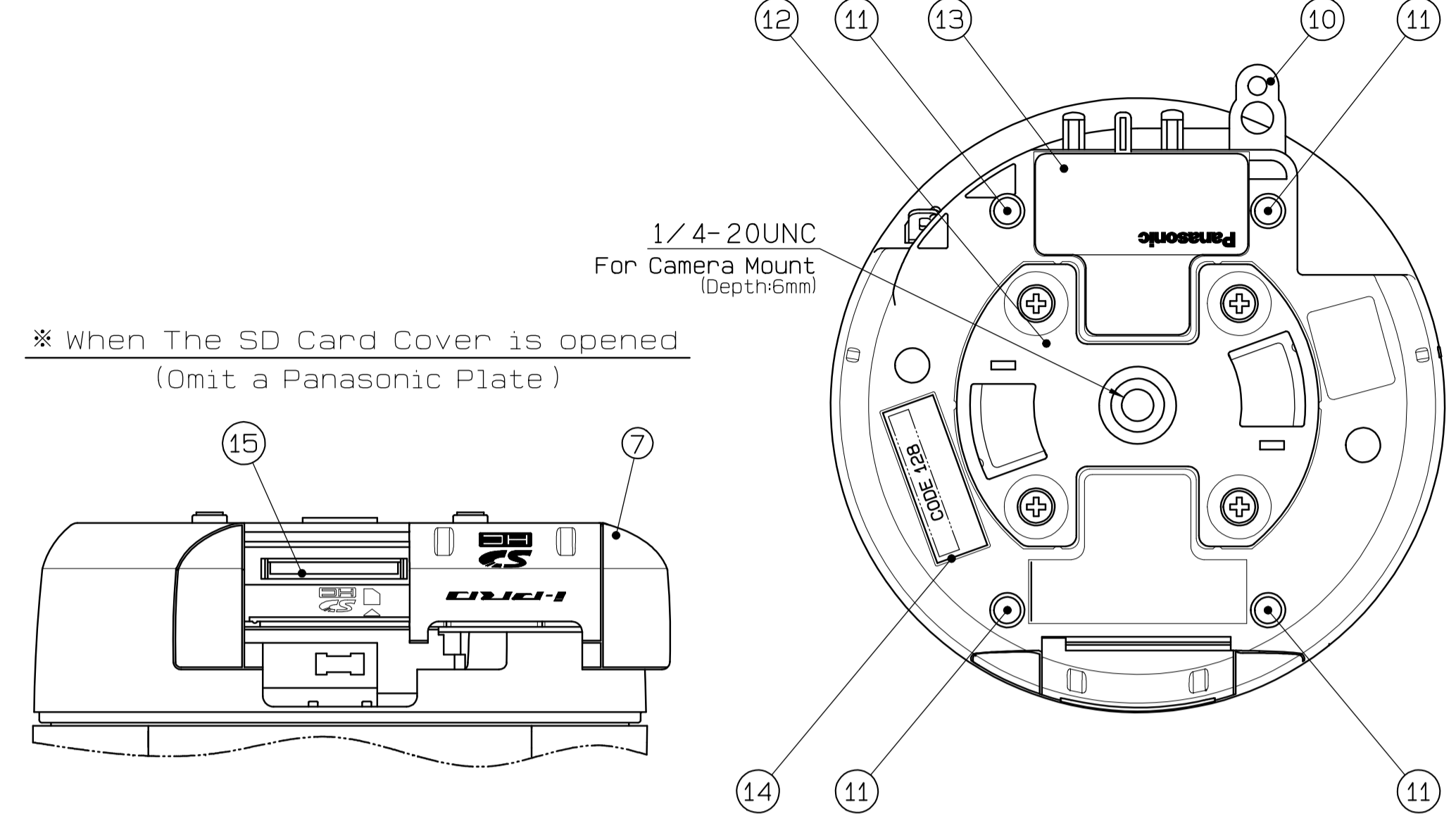
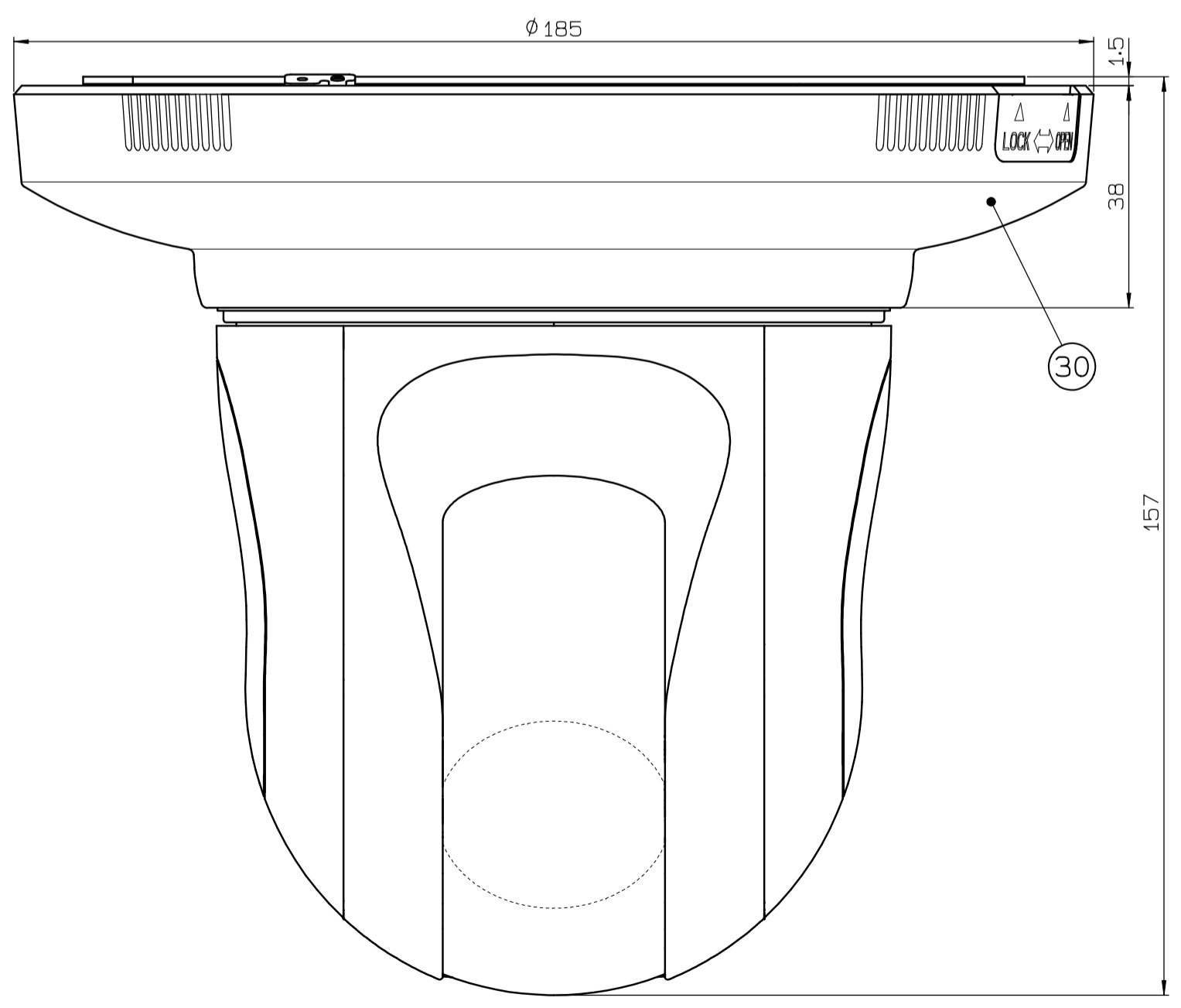
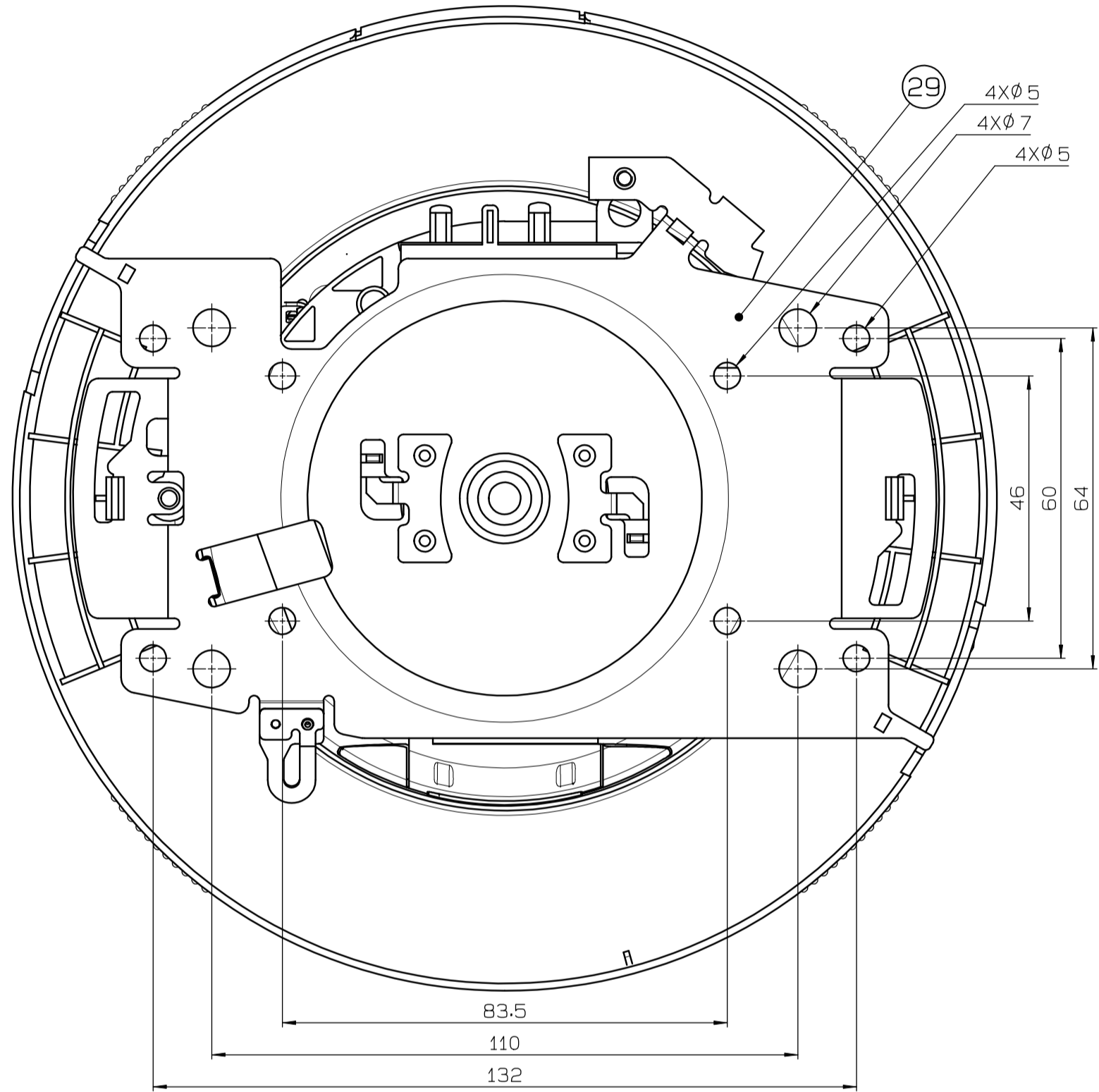
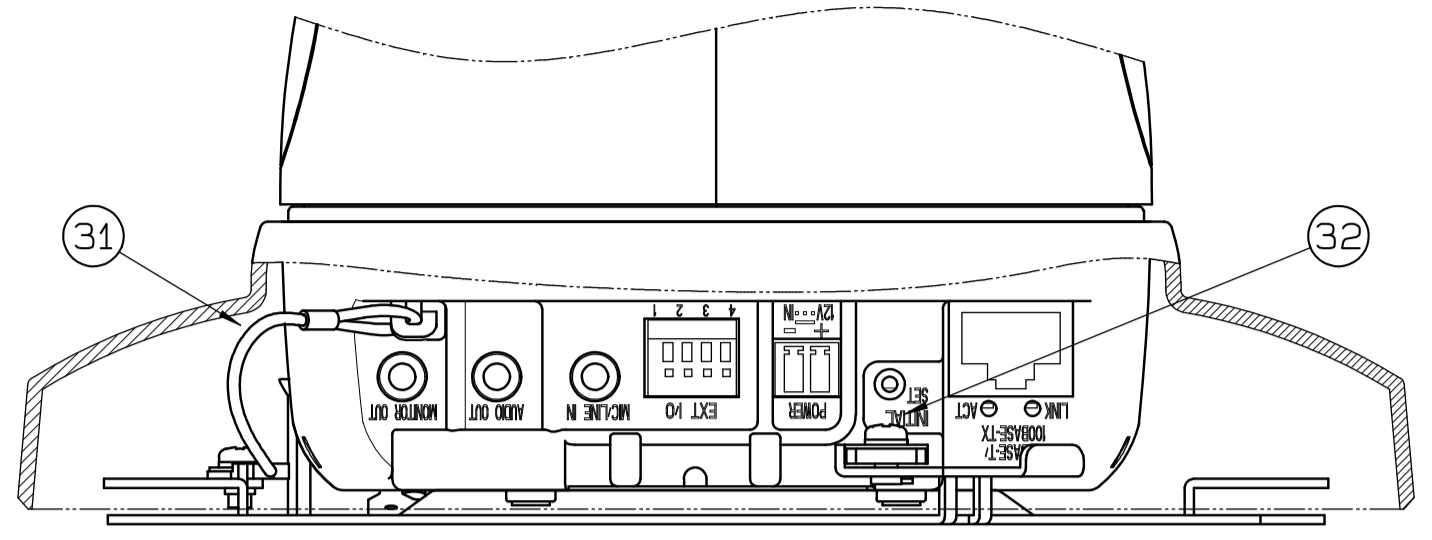

Filename:

SYM	ITEM OR PARTS NO.	NAME	QTY	MATERIAL & SIZE	TREATMENT	REMARK
1	1					

Panasonic System Networks Co., Ltd.

REMARK	Weight: Approx 0.86kg	MODEL	WV-SC384H
SCALE 1:1	DESIGNED urshijima 10-10-18	DRAWN kobayashi 10-10-18	NAME APPEARANCE
			DRAWING/Part No. 110A2545AA
			REF. NO.

Unit:mm
Model File Name /
DWG File Name /